

PENTA

MOTORE C.C.

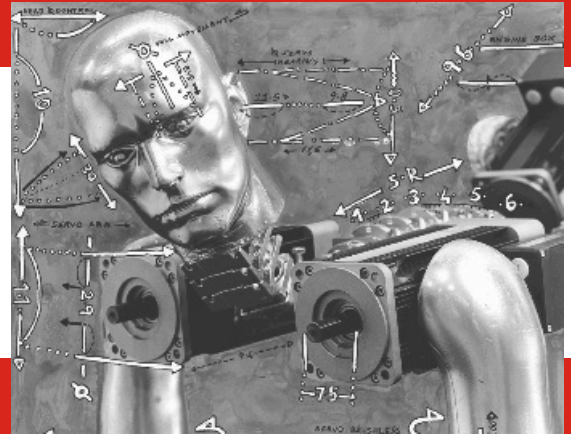
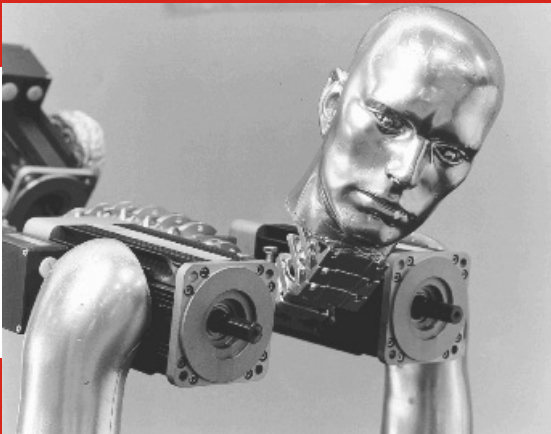

PENTA

Questa serie di motori a corrente continua, con potenze comprese tra 45 Watt e 1500 Watt, nasce da un'attenta analisi del mercato e rappresenta il giusto compromesso tra i fattori prestazione - prezzo qualità. Grazie a componenti quali il collettore rame-argento, le spazzole di lunga durata e i magneti permanenti in ferrite, magnetizzati e calibrati in sede, PENTA garantisce competitività per le prestazioni rese.



Tipo Motore	Potenza Watt		Coppia alla velocità Nominale (Nm)	Tensione (Vdc)	Forme Costruttive			Ventilazione		Dimensioni (mm)	
	3000 Rpm	2000 Rpm			B3	B5	B14	Naturale	Autoventil Protetta	Diametro	Lunghezza
PENTA 1S	45		0.14	24÷48	•		•	•		57.8	109.5
PENTA 1M	70		0.22		•		•	•			136
PENTA 1L	95		0.30		•	•	•	•			183.5
PENTA 4S	300	200	0.95	12÷180	•	•	•	•		116	197.5
PENTA 4M	600	400	1.9	24÷180	•	•	•	•			227.5
PENTA 4L	900	600	2.86		•	•	•	•			257.5
PENTA 5X	100	70	0.32	12÷180	•	•	•	•		83.5	144.5
PENTA 5XS	150	100	0.48		•	•	•	•			177.5
PENTA 5S	200	135	0.64		•	•	•	•			212.5
PENTA 5SL	300	200	0.96	24÷180	•	•	•	•			229
PENTA 5M	360	240	1.15	36÷180	•	•	•	•			267.5
PENTA 5L	500	335	1.6	48÷180	•	•	•	•			322.5
PENTA 5XA	150	100	0.48	12÷180	•	•	•		•	107	189.5
PENTA 5XSA	235	155	0.75		•	•	•		•		222.5
PENTA 5SA	300	200	0.96	24÷180	•	•	•		•		257.5
PENTA 5SLA	440	290	1.4		•	•	•		•		274
PENTA 5MA	565	375	1.8		•	•	•		•		312.5
PENTA 7SA	750	500	2.4	90÷180	•	•	•		•	116	318
PENTA 7MA	1100	750	3.5			•	•		•		390
PENTA 7LA	1500	1100	4.8	110÷180		•	•		•		462

Protezione IP 54

Isolamento classe F

Bassa rumorosità

Eccitazione a magneti permanenti in ferrite ad alta forza coercitiva

Rotore a chiave inclinate per una maggiore linearità

MOTORI IN CORRENTE CONTINUA

D.C. MOTORS

SERIE
Series

PENTA

1M

W	RPM
70	3000
	2000

CARATTERISTICHE GENERALI - Performance characteristics

TIPO MOTORE		1M30																		
Motor type		1M30																		
POTENZA RESA	P _{nom}																			
Rated power	[W]				70															
VELOCITA' NOMINALE	N _{nom}																			
Rated speed	[rpm]				3000															2000
COPPIA NOMINALE	C _{nom}																			
Rated torque	[Nm]				0.22															
TENSIONE NOMINALE	V _{nom}																			
Rated voltage	[V]				48	36	24													
CORRENTE NOMINALE	I _{nom}																			
Rated current	[A]				1.95	2.6	3.65													
COPPIA MASSIMA	C _{max}																			
Peak torque	[Nm]				1.1	1.1	1.1													
CORRENTE MASSIMA	I _{max}																			
Peak current	[A]				9.75	13	18.25													
RESISTENZA ARMATURA	R _{arm}																			
Armature resistance	[Ohm]				2.33	1.85	0.85													
INDUTTANZA ARMATURA	L _a																			
Armature inductance	[mH]				4	3	1.34													
COST. TENSIONE	K _e																			
Voltage constant	[V/Krpm]				13.2	10.4	7.3													
COST. TEMPO ELET.	T _e																			
Elect.time constant	[ms]				1.7	1.62	1.58													
COST. TEMPO MECC.	T _m																			
Mech.time constant	[ms]				6.5	6	6													

* Solo per servizio intermittente - Only intermittent duty

DATI MECCANICI - Mechanical data

INERZIA ROTORE	J _m					
Rotor inertia	[Kgc ²]				0.324	
MAX ACC. TEORICA						
Max theor. Acc.	[Rad/sec ²]				33950	
CARICO RADIALE MAX	R _I					
Max radial load	[N]				196	
CARICO ASSIALE MAX	A _I					
Max axial load	[N]				58	
PESO MOTORE	G					
Motor weight	[Kg]				1.3	
VENTILAZIONE					NATURALE	
Ventilation					T.E.N.V.	
GRADO DI PROTEZIONE						
Class protection	IP				54	

DATI ELETTRICI - Winding data

COST. DI TEMPO TERMICO	T _t				
Thermal time constant	[min]				25
MAX VEL. SENZA CARICO	No max				
Max no load speed	[rpm]				4000
MAX VEL. CON CARICO	N max				
Max load speed	[rpm]				3000
CLASSE D'ISOLAMENTO					
Insulation class					F
FATTORE DI SERVIZIO					
Duty cycle					S1
FATTORE DI FORMA					
Form factor	FF				1
TEMP. AMBIENTE RIF. DATI	T _{rif}				
Room temp. data refer.	[°C]				40°

MOTORI IN CORRENTE CONTINUA

D.C. MOTORS

SERIE
Series

PENTA

1L

W	RPM
95	3000
	2000

CARATTERISTICHE GENERALI - Performance characteristics

TIPO MOTORE		1L 30																		
Motor type		1L 30																		
POTENZA RESA	Pnom																			
Rated power	[W]				95															
VELOCITA' NOMINALE	Nnom																			
Rated speed	[rpm]				3000															
COPPIA NOMINALE	Cnom																			
Rated torque	[Nm]				0.3															
TENSIONE NOMINALE	Vnom																			
Rated voltage	[V]				48	36	24													
CORRENTE NOMINALE	Inom																			
Rated current	[A]				2.5	3.4	4.9													
COPPIA MASSIMA	Cmax																			
Peak torque	[Nm]				1.5	1.5	1.5													
CORRENTE MASSIMA	Imax																			
Peak current	[A]				12.5	17	24.5													
RESISTENZA ARMATURA	Rarm																			
Armature resistance	[Ohm]				2.43	1.19	0.48													
INDUTTANZA ARMATURA	La																			
Armature inductance	[mH]				3	1.65	0.7													
COST. TENSIONE	Ke																			
Voltage constant	[V/Krpm]				13.3	10.7	7.5													
COST. TEMPO ELET.	Te																			
Elect.time constant	[ms]				1.24	1.4	1.46													
COST. TEMPO MECC.	Tm																			
Mech.time constant	[ms]				9	7	6													

* Solo per servizio intermittente - Only intermittent duty

DATI MECCANICI - Mechanical data

INERZIA ROTORE	Jm			
Rotor inertia	[Kgcm ²]			0.607
MAX ACC. TEORICA				
Max theor. Acc.	[Rad/sec ²]			24711
CARICO RADIALE MAX	Rl			
Max radial load	[N]			196
CARICO ASSIALE MAX	Al			
Max axial load	[N]			58
PESO MOTORE	G			
Motor weight	[Kg]			1,85
VENTILAZIONE			NATURALE	
Ventilation			T.E.N.V.	
GRADO DI PROTEZIONE				
Class protection	IP			54

DATI ELETTRICI - Winding data

COST. DI TEMPO TERMICO	Tt			
Thermal time constant	[min]			30
MAX VEL. SENZA CARICO	No max			
Max no load speed	[rpm]			4000
MAX VEL. CON CARICO	N max			
Max load speed	[rpm]			3000
CLASSE D'ISOLAMENTO				
Insulation class				F
FATTORE DI SERVIZIO				
Duty cycle				S1
FATTORE DI FORMA				
Form factor	FF			1
TEMP. AMBIENTE RIF. DATI	T rif			
Room temp. data refer.	[°C]			40°

PENTA 1

MOTORI C.C.

D.C. MOTORS

DIMENSIONI (mm) DIMENSIONS (mm)

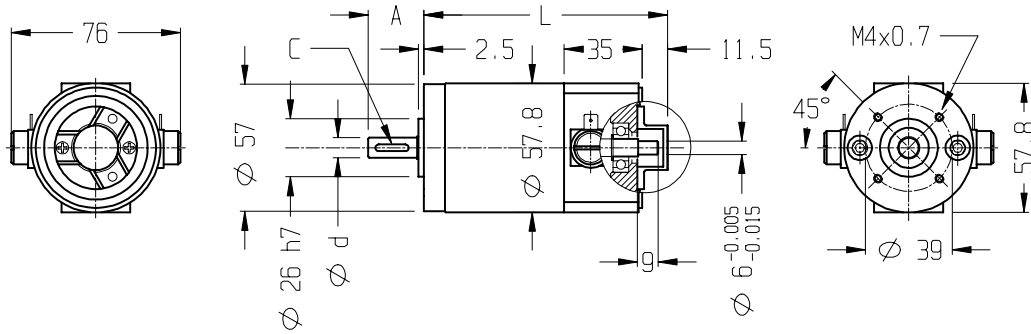

Type	S	M	L
A	20		25
L	109.5	136	183.5
d (j6)	7		9
C	-		3x3x15

MORSETTIERA

TERMINAL BOX

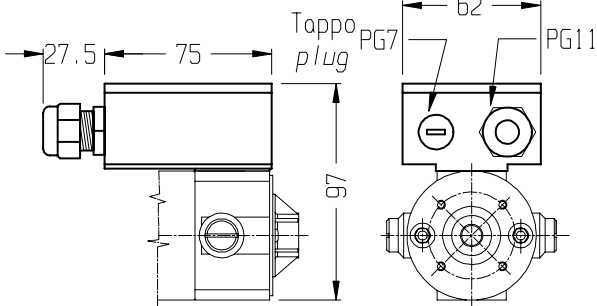

CONNETTORE

CONNECTOR

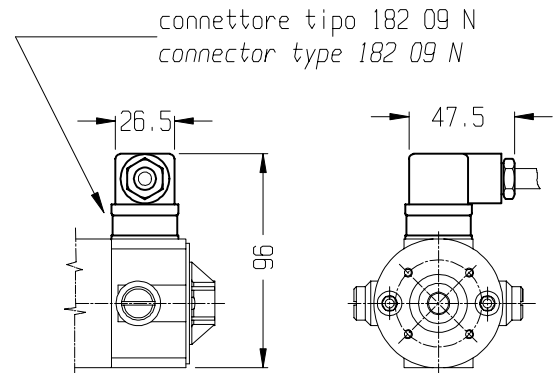

CAVO

FLYING LEADS

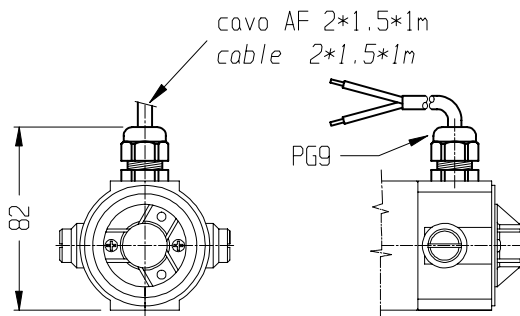

FLANGIA B14/56

B14/56 FLANGE

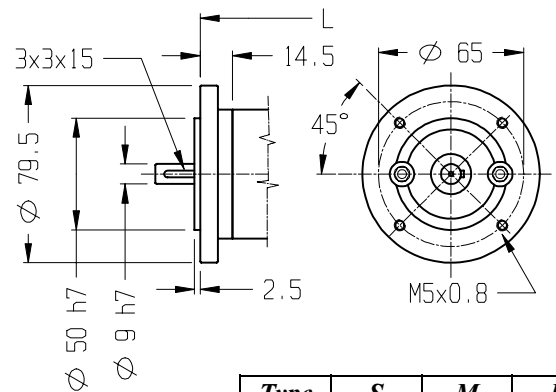

Type	S	M	L
L	114.5	141	188.5

PENTA 1

MOTORI C.C.

D.C. MOTORS

OPTIONALS

PIEDE A FASCIA

FOOT BAND TYPE

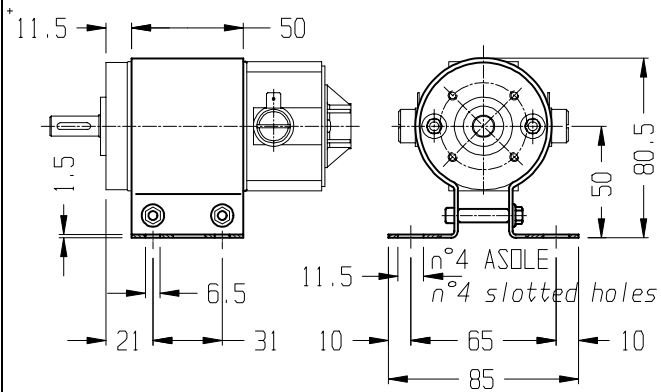

PRED. ENCODER

ENC. PREARRANGEMENT

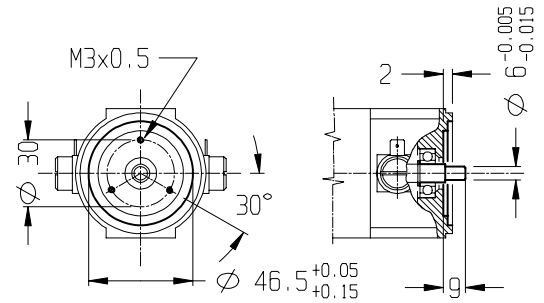

ENCODER EH53

EH53 ENCODER

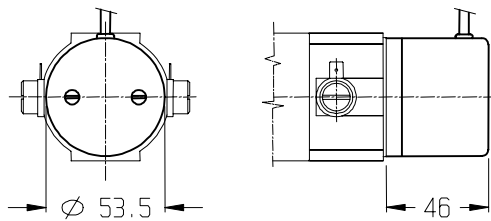

ENCODER EH38

EH38 ENCODER

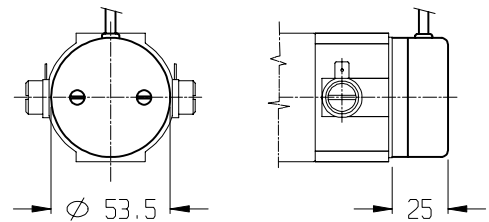

DISTANZ. ENC. N°1

ENCODER SPACER N°1

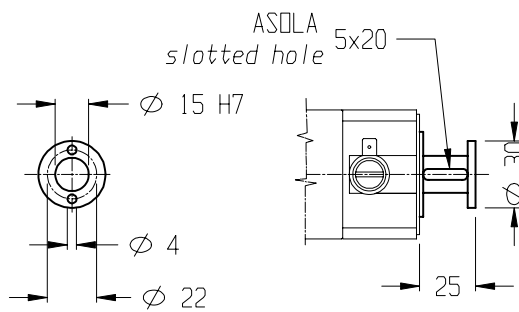

DISTANZ. ENC. N°2

ENCODER SPACER N°2

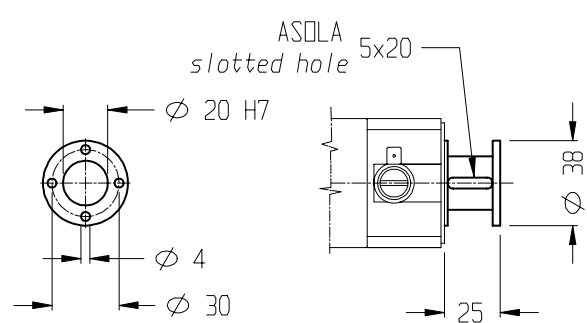

PENTA 1

MOTORI C.C.

D.C. MOTORS

OPTIONALS

DIN. TACHIMETRICA TACHO GENERATOR

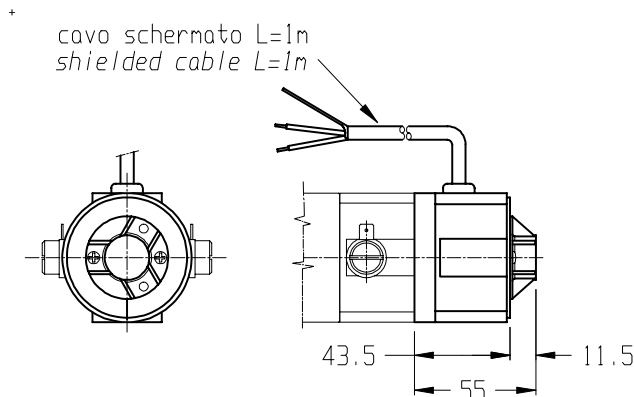

PREDISPOSTO ENCODER ENCODER PREARRANGEMENT

COSTANTE DI TENSIONE VOLTAGE CONSTANT	10±5% V/KRPM	CORRENTE NOMINALE RATED CURRENT	2 mA
VELOCITA' MASSIMA MAX SPEED	9000 RPM	CORRENTE MASSIMA MAX CURRENT	8 mA

FRENO 0.5 Nm BRAKE 0.5 Nm

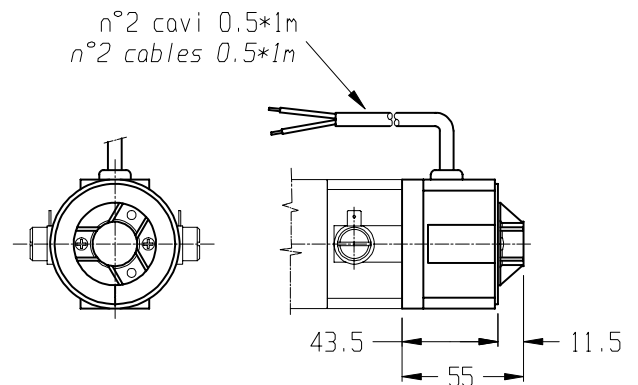

PREDISPOSTO ENCODER ENCODER PREARRANGEMENT

COPPIA STATICA STATIC TORQUE	0.5 Nm	CORRENTE CURRENT	0.42 A
TENSIONE DI ALIMEN. POWER SUPPLY VOLTAGE	24 V.c.c.	POTENZA ASSORBITA INPUT POWER	10 W

FRENO 0.5 Nm + DIN. TACHO GENERATOR + TACHIMETRICA BRAKE 0.5 Nm

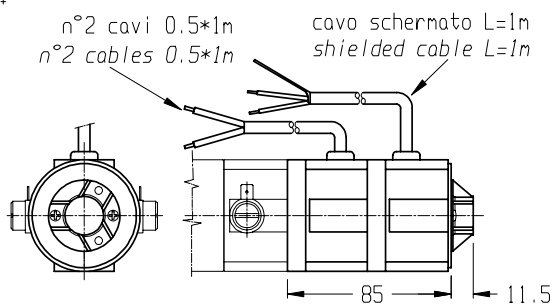

PREDISPOSTO ENCODER ENCODER PREARRANGEMENT

	FRENO BRAKE	DINAMO T. TACHO G.	
COPPIA STATICA STATIC TORQUE	0.5 Nm	COSTANTE DI TENSIONE VOLTAGE CONSTANT	10±5% V/KRPM
TENSIONE DI ALIMEN. POWER SUPPLY VOLTAGE	24 V.c.c.	VELOCITA' MASSIMA MAX SPEED	9000 RPM
CORRENTE CURRENT	0.42 A	CORRENTE NOMINALE RATED CURRENT	2 mA
POTENZA ASSORBITA INPUT POWER	10 W	CORRENTE MASSIMA MAX CURRENT	8 mA

MOTORI IN CORRENTE CONTINUA

D.C. MOTORS

SERIE
Series

PENTA 4S

W	RPM
300	3000
200	2000

CARATTERISTICHE GENERALI - Performance characteristics

TIPO MOTORE	4S 30								4S20								
Motor type	4S 30								4S20								
POTENZA RESA	P _{nom}	300								200							
Rated power	[W]	300								200							
VELOCITA' NOMINALE	N _{nom}	3000								2000							
Rated speed	[rpm]	3000								2000							
COPPIA NOMINALE	C _{nom}	0.95								0.95							
Rated torque	[Nm]	0.95								0.95							
TENSIONE NOMINALE	V _{nom}	180	90	60	48	36	24	12	180	90	60	48	36	24	12		
Rated voltage	[V]	180	90	60	48	36	24	12	180	90	60	48	36	24	12		
CORRENTE NOMINALE	I _{nom}	2.22	4.44	6.67	8.33	11.11	16.67	33.33	1.48	2.96	4.44	5.56	7.41	11.11	22.22		
Rated current	[A]	2.22	4.44	6.67	8.33	11.11	16.67	33.33	1.48	2.96	4.44	5.56	7.41	11.11	22.22		
COPPIA MASSIMA	C _{max}	4.76								4.76							
Peak torque	[Nm]	4.76								4.76							
CORRENTE MASSIMA	I _{max}	11.1	22.2	33.3	41.7	55.6	83.3	166.7	7.4	14.8	22.2	27.8	37.0	55.6	111.1		
Peak current	[A]	11.1	22.2	33.3	41.7	55.6	83.3	166.7	7.4	14.8	22.2	27.8	37.0	55.6	111.1		
RESISTENZA ARMATURA	R _{arm}	7.36	1.91	1.19	0.91	0.62	0.23	0.09	16.99	3.66	1.94	1.92	1.20	0.47	0.16		
Armature resistance	[Ohm]	7.36	1.91	1.19	0.91	0.62	0.23	0.09	16.99	3.66	1.94	1.92	1.20	0.47	0.16		
INDUTTANZA ARMATURA	L _a	30.00	7.50	3.59	0.90	0.51	0.23	0.06	80.00	19.50	8.67	2.05	1.12	0.51	0.14		
Armature inductance	[mH]	30.00	7.50	3.59	0.90	0.51	0.23	0.06	80.00	19.50	8.67	2.05	1.12	0.51	0.14		
COST. TENSIONE	K _e	54.5	27.3	18.2	14.5	10.6	7.1	3.5	81.8	40.9	27.3	21.8	15.9	10.6	5.2		
Voltage constant	[V/Krpm]	54.5	27.3	18.2	14.5	10.6	7.1	3.5	81.8	40.9	27.3	21.8	15.9	10.6	5.2		
COST. TEMPO ELET.	T _e	4.08	3.93	3.02	0.99	0.81	0.98	0.59	4.71	5.32	4.47	1.07	0.93	1.09	0.88		
Elect.time constant	[ms]	4.08	3.93	3.02	0.99	0.81	0.98	0.59	4.71	5.32	4.47	1.07	0.93	1.09	0.88		
COST. TEMPO MECC.	T _m	31.2	32.3	45.4	54.4	69.8	58.1	98.9	32.0	27.6	32.9	50.8	60.1	53.0	74.3		
Mech.time constant	[ms]	31.2	32.3	45.4	54.4	69.8	58.1	98.9	32.0	27.6	32.9	50.8	60.1	53.0	74.3		

* Solo per servizio intermittente - Intermittent duty only

DATI MECCANICI - Mechanical data

INERZIA ROTORE	J _m	0.00115
Rotor inertia	[Kgm ²]	0.00115
MAX ACC. TEORICA	[Rad/sec ²]	4141
Max theor. Acc.	[Rad/sec ²]	4141
CARICO RADIALE MAX	R _I	360
Max radial load	[N]	360
CARICO ASSIALE MAX	A _I	108
Max axial load	[N]	108
PESO MOTORE	G	5.3
Motor weight	[Kg]	5.3
VENTILAZIONE	NATURALE	
Ventilation	T.E.N.V.	
GRADO DI PROTEZIONE	IP	54
Class protection	IP	54

DATI ELETTRICI - Winding data

COST. DI TEMPO TERMICO	T _t	30
Thermal time constant	[min]	30
MAX VEL. SENZA CARICO	No max	4000
Max no load speed	[rpm]	4000
MAX VEL. CON CARICO	N max	3000
Max load speed	[rpm]	3000
CLASSE D'ISOLAMENTO	F	
Insulation class	F	
FATTORE DI SERVIZIO	S1	
Duty cycle	S1	
FATTORE DI FORMA	FF	1
Form factor	FF	1
TEMP. AMBIENTE RIF. DATI	T _{rif}	40°
Room temp. data refer.	[°C]	40°

MOTORI IN CORRENTE CONTINUA

D.C. MOTORS

SERIE
Series

PENTA 4M

W	RPM
600	3000
400	2000

CARATTERISTICHE GENERALI - Performance characteristics

TIPO MOTORE	4M 30								4M20								
Motor type	4M 30								4M20								
POTENZA RESA	P _{nom}	600								400							
Rated power	[W]	600								400							
VELOCITA' NOMINALE	N _{nom}	3000								2000							
Rated speed	[rpm]	3000								2000							
COPPIA NOMINALE	C _{nom}	1.90								1.90							
Rated torque	[Nm]	1.90								1.90							
TENSIONE NOMINALE	V _{nom}	180	90	60	48	36	24	12*	180	90	60	48	36	24	12*		
Rated voltage	[V]	180	90	60	48	36	24	12*	180	90	60	48	36	24	12*		
CORRENTE NOMINALE	I _{nom}	4.44	8.89	13.33	16.67	22.22	33.33	66.67	2.96	5.93	8.89	11.11	14.81	22.22	44.44		
Rated current	[A]	4.44	8.89	13.33	16.67	22.22	33.33	66.67	2.96	5.93	8.89	11.11	14.81	22.22	44.44		
COPPIA MASSIMA	C _{max}	9.52								9.52							
Peak torque	[Nm]	9.52								9.52							
CORRENTE MASSIMA	I _{max}	22.2	44.4	66.7	83.3	111.1	166.7	333.3	14.8	29.6	44.4	55.6	74.1	111.1	222.2		
Peak current	[A]	22.2	44.4	66.7	83.3	111.1	166.7	333.3	14.8	29.6	44.4	55.6	74.1	111.1	222.2		
RESISTENZA ARMATURA	R _{arm}	2.84	0.96	0.59	0.52	0.40	0.13	0.08	4.79	1.62	0.81	0.95	0.54	0.23	0.11		
Armature resistance	[Ohm]	2.84	0.96	0.59	0.52	0.40	0.13	0.08	4.79	1.62	0.81	0.95	0.54	0.23	0.11		
INDUTTANZA ARMATURA	L _a	12.80	2.98	1.23	0.45	0.28	0.11	0.02	27.00	6.75	3.00	1.05	0.54	0.24	0.06		
Armature inductance	[mH]	12.80	2.98	1.23	0.45	0.28	0.11	0.02	27.00	6.75	3.00	1.05	0.54	0.24	0.06		
COST. TENSIONE	K _e	56.3	27.3	18.2	14.5	10.6	7.1	3.5	81.8	40.9	27.3	21.8	15.9	10.6	5.2		
Voltage constant	[V/Krpm]	56.3	27.3	18.2	14.5	10.6	7.1	3.5	81.8	40.9	27.3	21.8	15.9	10.6	5.2		
COST. TEMPO ELET.	T _e	4.50	3.12	2.09	0.87	0.70	0.87	0.25	5.64	4.16	3.72	1.10	0.99	1.04	0.56		
Elect.time constant	[ms]	4.50	3.12	2.09	0.87	0.70	0.87	0.25	5.64	4.16	3.72	1.10	0.99	1.04	0.56		
COST. TEMPO MECC.	T _m	20.2	28.9	40.2	55.3	79.4	58.6	156.6	16.1	21.8	24.4	44.9	48.4	45.8	88.5		
Mech.time constant	[ms]	20.2	28.9	40.2	55.3	79.4	58.6	156.6	16.1	21.8	24.4	44.9	48.4	45.8	88.5		

* Solo per servizio intermittente - Intermittent duty only

DATI MECCANICI - Mechanical data

INERZIA ROTORE	J _m	0.00205
Rotor inertia	[Kgm ²]	0.00205
MAX ACC. TEORICA		4646
Max theor. Acc.	[Rad/sec ²]	4646
CARICO RADIALE MAX	R _I	360
Max radial load	[N]	360
CARICO ASSIALE MAX	A _I	108
Max axial load	[N]	108
PESO MOTORE	G	6,8
Motor weight	[Kg]	6,8
VENTILAZIONE		NATURALE
Ventilation		T.E.N.V.
GRADO DI PROTEZIONE		54
Class protection	IP	54

DATI ELETTRICI - Winding data

COST. DI TEMPO TERMICO	T _t	40
Thermal time constant	[min]	40
MAX VEL. SENZA CARICO	No max	4000
Max no load speed	[rpm]	4000
MAX VEL. CON CARICO	N max	3000
Max load speed	[rpm]	3000
CLASSE D'ISOLAMENTO		F
Insulation class		F
FATTORE DI SERVIZIO		S1
Duty cycle		S1
FATTORE DI FORMA	FF	1
Form factor	FF	1
TEMP. AMBIENTE RIF. DATI	T _{rif}	40°
Room temp. data refer.	[°C]	40°

MOTORI IN CORRENTE CONTINUA

D.C. MOTORS

SERIE
Series

PENTA 4L

W	RPM
900	3000
600	2000

CARATTERISTICHE GENERALI - Performance characteristics

TIPO MOTORE	4L 30								4L20									
Motor type	4L 30								4L20									
POTENZA RESA	P _{nom}																	
Rated power	[W]		900								600							
VELOCITA' NOMINALE	N _{nom}																	
Rated speed	[rpm]		3000								2000							
COPPIA NOMINALE	C _{nom}																	
Rated torque	[Nm]		2.86								2.86							
TENSIONE NOMINALE	V _{nom}																	
Rated voltage	[V]		180	90	60	48	36	24*	12*	180	90	60	48	36	24	12*		
CORRENTE NOMINALE	I _{nom}																	
Rated current	[A]		6.67	13.33	20.00	25.00	33.33	50.00	100.00	4.44	8.89	13.33	16.67	22.22	33.33	66.67		
COPPIA MASSIMA	C _{max}																	
Peak torque	[Nm]		14.29								14.29							
CORRENTE MASSIMA	I _{max}																	
Peak current	[A]		33.3	66.7	100.00	125.0	166.7	250.0	500.0	22.2	44.4	66.7	83.3	111.1	166.7	333.3		
RESISTENZA ARMATURA	R _{arm}																	
Armature resistance	[Ohm]		1.73	0.69	0.45	0.36	0.28	0.11	0.07	2.50	0.85	0.49	0.53	0.36	0.13	0.09		
INDUTTANZA ARMATURA	L _a																	
Armature inductance	[mH]		7.50	1.88	0.35	0.25	0.12	0.06	0.01	12.70	3.18	1.52	0.48	0.24	0.12	0.02		
COST. TENSIONE	K _e																	
Voltage constant	[V/Krpm]		57.1	27.3	18.2	14.5	10.6	7.1	3.5	81.8	40.9	27.3	21.8	15.9	10.6	5.2		
COST. TEMPO ELET.	T _e																	
Elect.time constant	[ms]		4.34	2.70	0.78	0.67	0.42	0.56	0.13	5.08	3.75	3.08	0.90	0.67	0.90	0.26		
COST. TEMPO MECC.	T _m																	
Mech.time constant	[ms]		16.8	29.7	43.5	54.7	80.2	69.6	193.6	11.9	16.1	21.1	35.5	45.8	37.7	99.9		

* Solo per servizio intermittente - Intermittent duty only

DATI MECCANICI - Mechanical data

INERZIA ROTORE	J _m	
Rotor inertia	[Kgm ²]	0.0029
MAX ACC. TEORICA		
Max theor. Acc.	[Rad/sec ²]	4946
CARICO RADIALE MAX	R _I	
Max radial load	[N]	360
CARICO ASSIALE MAX	A _I	
Max axial load	[N]	108
PESO MOTORE	G	
Motor weight	[Kg]	8,3
VENTILAZIONE		NATURALE
Ventilation		T.E.N.V.
GRADO DI PROTEZIONE		
Class protection	IP	54

DATI ELETTRICI - Winding data

COST. DI TEMPO TERMICO	T _t	
Thermal time constant	[min]	60
MAX VEL. SENZA CARICO	No max	
Max no load speed	[rpm]	4000
MAX VEL. CON CARICO	N max	
Max load speed	[rpm]	3000
CLASSE D'ISOLAMENTO		
Insulation class		F
FATTORE DI SERVIZIO		
Duty cycle		S1
FATTORE DI FORMA		
Form factor	FF	1
TEMP. AMBIENTE RIF. DATI	T _{rif}	
Room temp. data refer.	[°C]	40°

PENTA 4

MOTORI C.C.

D.C. MOTORS

DIMENSIONI (mm) DIMENSIONS (mm)

PIEDE

FOOT

Type	S	M	L
L	197.5	227.5	257.5

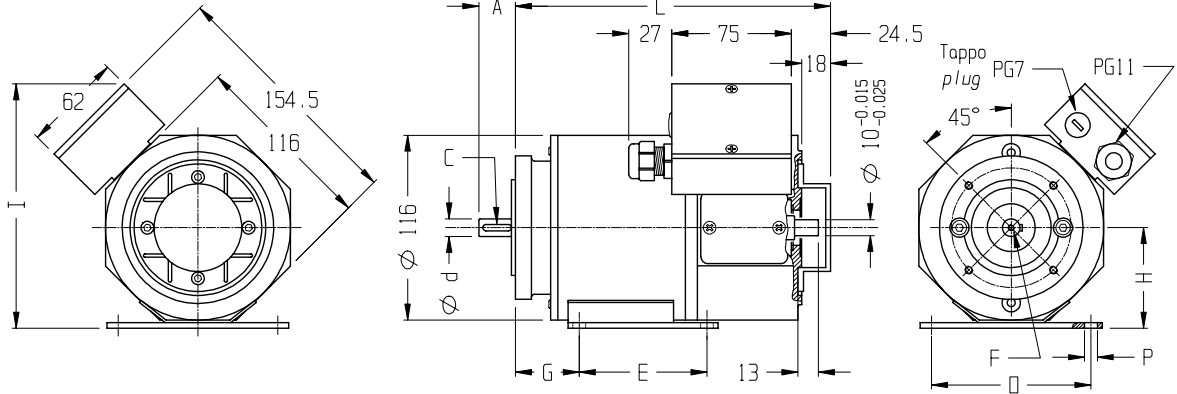

Size	A	C	d(h7)	E	F	G	H	I	O	P
63	23	4x4x18	11	80	M4	40	63	153	100	8
71	30	5x5x25	14	90	M5	45	71	161	112	9

FLANGIA B14

B14 FLANGE

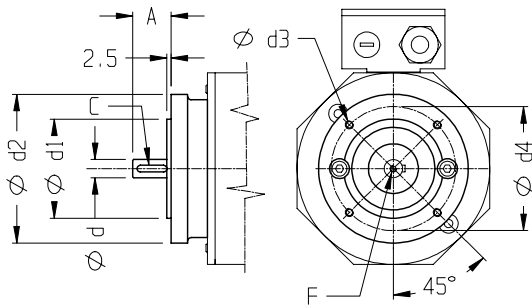

Size	A	C	d(h7)	d1(h7)	d2	d3	d4	F
56	20	3x3x15	9	50	80	M5	65	-
63	23	4x4x18	11	60	90	M5	75	M4
71	30	5x5x25	14	70	105	M6	85	M5

FLANGIA B5

B5 FLANGE

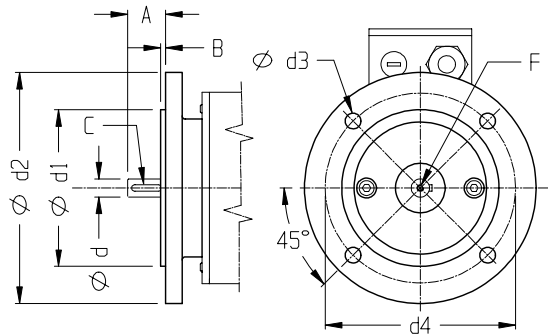

Size	A	B	C	d(h7)	d1(h7)	d2	d3	d4	F
56	20	3	3x3x15	9	80	120	8.5	100	-
63	23	3	4x4x18	11	95	140	9.5	115	M4
71	30	3.5	5x5x25	14	110	160	9.5	130	M5

CONNETTORE

CONNECTOR

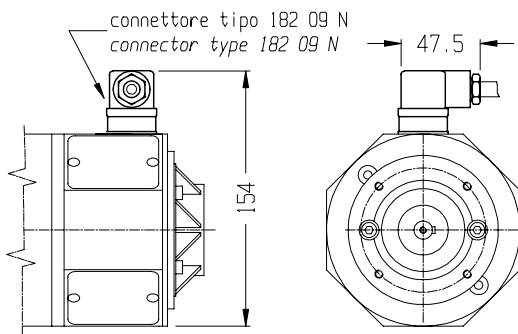

CAVO

FLYING LEADS

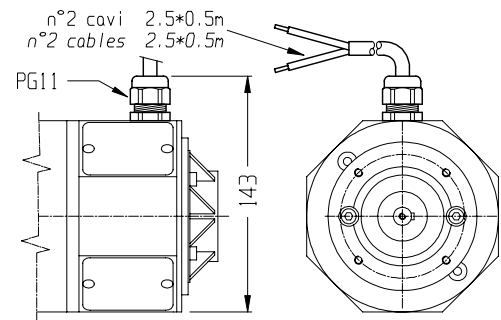

PENTA 4

MOTORI C.C.

D.C. MOTORS

OPTIONALS

PRED. ENCODER *ENC. PREARRANGEMENT*

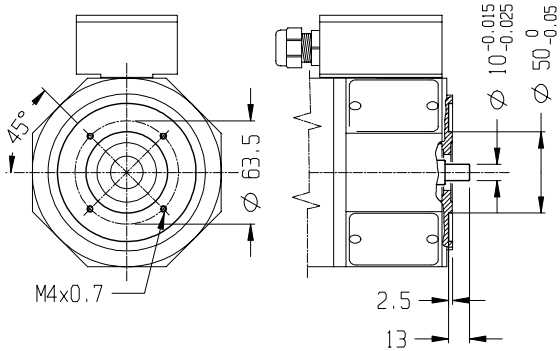

ENCODER EL72

EL72 ENCODER

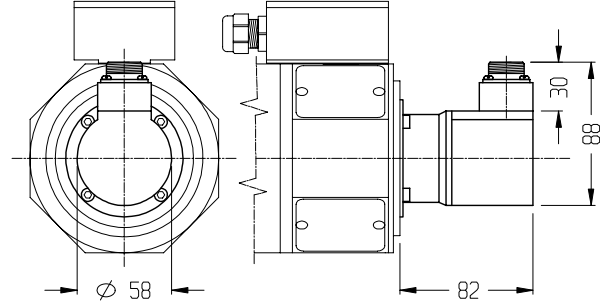

DISTANZ. ENC. N°1

ENC. SPACER N°1

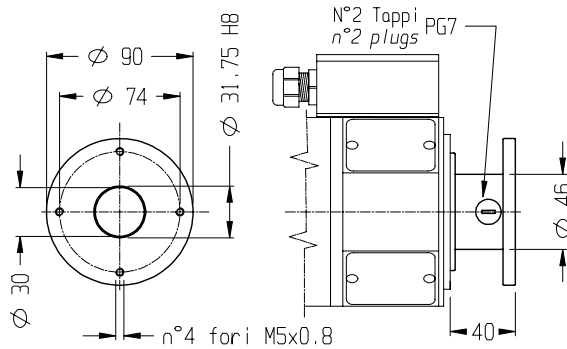

DIN. TACHIMETRICA

TACHO GENERATOR

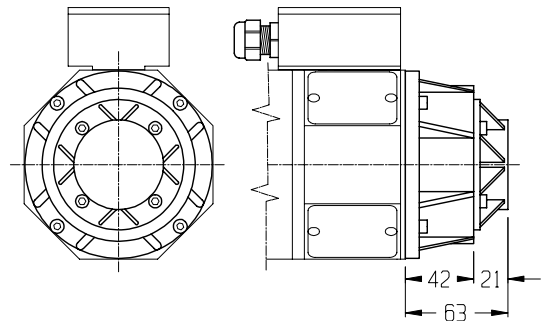

COSTANTE DI TENSIONE <i>VOLTAGE CONSTANT</i>	10±5% V/KRPM	CORRENTE NOMINALE <i>RATED CURRENT</i>	2 mA
VELOCITA' MASSIMA <i>MAX SPEED</i>	9000 RPM	CORRENTE MASSIMA <i>MAX CURRENT</i>	8 mA

FRENO N°1: 1,7 Nm

BRAKE N°1: 1,7 Nm

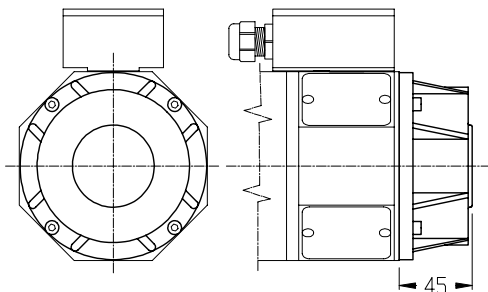

COPPIA STATICA <i>STATIC TORQUE</i>	1,7 Nm	CORRENTE <i>CURRENT</i>	0.46-0.058 A
TENSIONE DI ALIMEN. <i>POWER SUPPLY VOLTAGE</i>	24-190 V.c.c.	POTENZA ASSORBITA <i>INPUT POWER</i>	11 W

FRENO N°2: 4 Nm

BRAKE N°2: 4 Nm

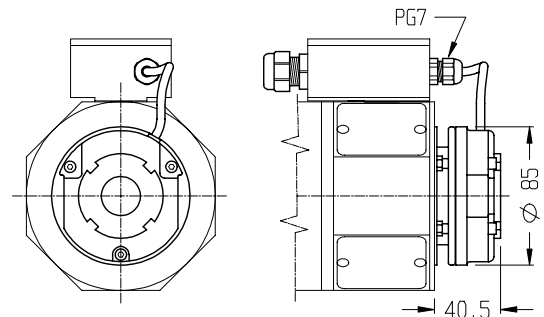

COPPIA STATICA <i>STATIC TORQUE</i>	4 Nm	CORRENTE <i>CURRENT</i>	0.83-0.109 A
TENSIONE DI ALIMEN. <i>POWER SUPPLY VOLTAGE</i>	24-190 V.c.c.	POTENZA ASSORBITA <i>INPUT POWER</i>	20 W

MOTORI IN CORRENTE CONTINUA

D.C. MOTORS

SERIE
Series

PENTA

5X

W	RPM
100	3000
70	2000

CARATTERISTICHE GENERALI - Performance characteristics

TIPO MOTORE		5X 30								5X20							
Motor type																	
POTENZA RESA	Pnom																
Rated power	[W]	100								70							
VELOCITA' NOMINALE	Nnom																
Rated speed	[rpm]	3000								2000							
COPPIA NOMINALE	Cnom																
Rated torque	[Nm]	0.32								0.32							
TENSIONE NOMINALE	Vnom																
Rated voltage	[V]	180	90	60	48	36	24	12	180	90	60	48	33	24	12		
CORRENTE NOMINALE	Inom																
Rated current	[A]	0.74	1.5	2.2	2.8		5.54	11	0.55	1.1	1.6	2	2.8	4	8		
COPPIA MASSIMA	Cmax																
Peak torque	[Nm]	1.6	1.6	1.6	1.6		1.6	1.6	1.6	1.6	1.6	1.6	1.6	1.6	1.6		
CORRENTE MASSIMA	Imax																
Peak current	[A]	3.7	7.5	11	14		27.7	55	2.75		8	10	14	20	40		
RESISTENZA ARMATURA	Rarm																
Armature resistance	[Ohm]	16.7	4.1	1.8	1.28		0.4	0.12	41.1		4.1	2.4	1.28	0.86	0.25		
INDUTTANZA ARMATURA	La																
Armature inductance	[mH]	46.5	10.25	4.15	2.95		0.8	0.19	135	35.4	10.25	5.75	2.95	1.75	0.5		
COST. TENSIONE	Ke																
Voltage constant	[V/Krpm]	54	27	17	15		7	3.4	82	40	26	20	15	9.6	5		
COST. TEMPO ELET.	Te																
Elect.time constant	[ms]	2.8	2.5	2.3	2.3		2	1.6	3.3		2.5	2.4	2.3	2.1	1.6		
COST. TEMPO MECC.	Tm																
Mech.time constant	[ms]	11	11	12	11		16	20	12		11	12	11	15	19		

* Solo per servizio intermittente - Only intermittent duty

DATI MECCANICI - Mechanical data

INERZIA ROTORE	Jm	
Rotor inertia	[Kgm ²]	0.00018
MAX ACC. TEORICA		
Max theor. Acc.	[Rad/sec ²]	8800
CARICO RADIALE MAX	RI	
Max radial load	[N]	294
CARICO ASSIALE MAX	AI	
Max axial load	[N]	88
PESO MOTORE	G	
Motor weight	[Kg]	2.9
VENTILAZIONE		NATURALE
Ventilation		T.E.N.V.
GRADO DI PROTEZIONE		
Class protection	IP	54

DATI ELETTRICI - Winding data

COST. DI TEMPO TERMICO	Tt	
Thermal time constant	[min]	20
MAX VEL. SENZA CARICO	No max	
Max no load speed	[rpm]	4000
MAX VEL. CON CARICO	N max	
Max load speed	[rpm]	3000
CLASSE D'ISOLAMENTO		
Insulation class		F
FATTORE DI SERVIZIO		
Duty cycle		S1
FATTORE DI FORMA		
Form factor	FF	1
TEMP. AMBIENTE RIF. DATI	T rif	
Room temp. data refer.	[°C]	40°

MOTORI IN CORRENTE CONTINUA

D.C. MOTORS

SERIE
Series

PENTA

5XS

W	RPM
150	3000
100	2000

CARATTERISTICHE GENERALI - Performance characteristics

TIPO MOTORE		5XS 30								5XS 20							
MOTOR type																	
POTENZA RESA	P _{nom}																
Rated power	[W]	150								100							
VELOCITA' NOMINALE	N _{nom}																
Rated speed	[rpm]	3000								2000							
COPPIA NOMINALE	C _{nom}																
Rated torque	[Nm]	0.48								0.48							
TENSIONE NOMINALE	V _{nom}																
Rated voltage	[V]	180	90	60	48	36	24	12	180	90	60	48	36	24	12		
CORRENTE NOMINALE	I _{nom}																
Rated current	[A]	1.1	2.2	3.3	4.2	5.55	8.33	16	0.74	1.5	2.2	2.8	3.7	5.54	11		
COPPIA MASSIMA	C _{max}																
Peak torque	[Nm]	2.4	2.4	2.4	2.4	2.4	2.4	2.4	2.4	2.4	2.4	2.4		2.4	2.4		
CORRENTE MASSIMA	I _{max}																
Peak current	[A]	5.5		16.7	21		41.7	80	3.7		11	14		27.7	55		
RESISTENZA ARMATURA	R _{arm}																
Armature resistance	[Ohm]	13.9	4.04	1.64	1.1		0.29	0.12	26.9		3.5	2.6		0.54	0.184		
INDUTTANZA ARMATURA	L _a																
Armature inductance	[mH]	47	11	5.4	3.5	1.92	0.73	0.165	100	29	10.9	7.5	4.7	1.3	2.2		
COST. TENSIONE	K _e																
Voltage constant	[V/Krpm]	54		18	15		7	3.4	82		26	20		9.6	5		
COST. TEMPO ELET.	T _e																
Elect.time constant	[ms]	3.4	3.2	3.29	3.2	3.5	2.5	1.4	3.7	3.5	3.2	2.9	3.4	2.4	2.2		
COST. TEMPO MECC.	T _m																
Mech.time constant	[ms]	15		17	16		19	34	13		17	21		19	24		

* Solo per servizio intermittente - Only intermittent duty

DATI MECCANICI - Mechanical data

INERZIA ROTORE	J _m	
Rotor inertia	[Kg ^m ²]	0.0003
MAX ACC. TEORICA		
Max theor. Acc.	[Rad/sec ²]	8000
CARICO RADIALE MAX	R _I	
Max radial load	[N]	294
CARICO ASSIALE MAX	A _I	
Max axial load	[N]	88
PESO MOTORE	G	
Motor weight	[Kg]	3.5
VENTILAZIONE		NATURALE
Ventilation		T.E.N.V.
GRADO DI PROTEZIONE		
Class protection	IP	54

DATI ELETTRICI - Winding data

COST. DI TEMPO TERMICO	T _t	
Thermal time constant	[min]	25
MAX VEL. SENZA CARICO	No max	
Max no load speed	[rpm]	4000
MAX VEL. CON CARICO	N max	
Max load speed	[rpm]	3000
CLASSE D'ISOLAMENTO		
Insulation class		F
FATTORE DI SERVIZIO		
Duty cycle		S1
FATTORE DI FORMA		
Form factor	FF	1
TEMP. AMBIENTE RIF. DATI	T _{rif}	
Room temp. data refer.	[°C]	40°

MOTORI IN CORRENTE CONTINUA

D.C. MOTORS

SERIE
Series

PENTA

5S

W	RPM
200	3000
135	2000

CARATTERISTICHE GENERALI - Performance characteristics

TIPO MOTORE	5S 30								5S 20									
Motor type	5S 30								5S 20									
POTENZA RESA	Pnom																	
Rated power	[W]		200								135							
VELOCITA' NOMINALE	Nnom																	
Rated speed	[rpm]		3000								2000							
COPPIA NOMINALE	Cnom																	
Rated torque	[Nm]		0.64								0.64							
TENSIONE NOMINALE	Vnom																	
Rated voltage	[V]		180	90	60	48	36	24	12*	180	88	60	46	36	24	12		
CORRENTE NOMINALE	Inom																	
Rated current	[A]		1.4	2.85	4.3	5.3	7	10.7		0.97	2.1	2.9	3.8	4.8	7.25	14.5		
COPPIA MASSIMA	Cmax																	
Peak torque	[Nm]		3.2	3.2	3.2	3.2	3.2	3.2		3.2	3.2	3.2	3.2	3.2	3.2	3.2		
CORRENTE MASSIMA	Imax																	
Peak current	[A]		7		21.5	26.5		53.5		4.85	10.5	14.5	19		36	72.5		
RESISTENZA ARMATURA	Rarm																	
Armature resistance	[Ohm]		6.15		0.92	0.6		0.17		15.5	3	1.36	0.96	1.08	0.33	0.12		
INDUTTANZA ARMATURA	La																	
Armature inductance	[mH]		20	5.79	2.5	1.5	0.76	0.32		49	11	3.9	2.67	1.77	0.73	0.16		
COST. TENSIONE	Ke																	
Voltage constant	[V/Krpm]		54	28.5	18	15		7		82	40	26	20	16.6	9.6	5		
COST. TEMPO ELET.	Te																	
Elect.time constant	[ms]		3.3	3.33	2.7	2.5		1.9		3.2	3.7	2.9	2.8		2.2	1.7		
COST. TEMPO MECC.	Tm																	
Mech.time constant	[ms]		14		19	17		23		15	12	13	16		21	31		

* Solo per servizio intermittente - Only intermittent duty

DATI MECCANICI - Mechanical data

INERZIA ROTORE	Jm	
Rotor inertia	[Kg ^m ²]	0.0006
MAX ACC. TEORICA		
Max theor. Acc.	[Rad/sec ²]	5330
CARICO RADIALE MAX	RI	
Max radial load	[N]	294
CARICO ASSIALE MAX	AI	
Max axial load	[N]	88
PESO MOTORE	G	
Motor weight	[Kg]	4.6
VENTILAZIONE		NATURALE
Ventilation		T.E.N.V.
GRADO DI PROTEZIONE		
Class protection	IP	54

DATI ELETTRICI - Winding data

COST. DI TEMPO TERMICO	Tt	
Thermal time constant	[min]	30
MAX VEL. SENZA CARICO	No max	
Max no load speed	[rpm]	4000
MAX VEL. CON CARICO	N max	
Max load speed	[rpm]	3000
CLASSE D'ISOLAMENTO		
Insulation class		F
FATTORE DI SERVIZIO		
Duty cycle		S1
FATTORE DI FORMA		
Form factor	FF	1
TEMP. AMBIENTE RIF. DATI	T rif	
Room temp. data refer.	[°C]	40°

MOTORI IN CORRENTE CONTINUA

D.C. MOTORS

SERIE
Series

PENTA

5SL

W	RPM
300	3000
200	2000

CARATTERISTICHE GENERALI - Performance characteristics

TIPO MOTORE		5SL 30								5SL 20							
Motor type																	
POTENZA RESA	Pnom																
Rated power	[W]	300								200							
VELOCITA' NOMINALE	Nnom																
Rated speed	[rpm]	3000								2000							
COPPIA NOMINALE	Cnom																
Rated torque	[Nm]	0.96								0.96							
TENSIONE NOMINALE	Vnom																
Rated voltage	[V]	180	90	60	48	36	24	12*	180	90	60	48	36	24	12*		
CORRENTE NOMINALE	Inom																
Rated current	[A]	2.1	4.2	6.3	7.8	10.4	15.6		1.4	2.8	4.2	5.2	7	10.4			
COPPIA MASSIMA	Cmax																
Peak torque	[Nm]	4.8	4.8	4.8	4.8	4.8	4.8		4.8	4.8	4.8	4.8	4.8	4.8			
CORRENTE MASSIMA	Imax																
Peak current	[A]	10.5	21	31.5	39	52	78		7	14	21			52			
RESISTENZA ARMATURA	Rarm																
Armature resistance	[Ohm]	5.3	1.41	0.67	0.4	0.29	0.16		12.5	2.5	1.41			0.29			
INDUTTANZA ARMATURA	La																
Armature inductance	[mH]	18.5	4.1	2	1.2	0.7	0.32		42	9.46	4.1	2.74	1.45	0.7			
COST. TENSIONE	Ke																
Voltage constant	[V/Krpm]	55.5	27	19	15	11.4	7.5		84.5	40	27	21		11.4			
COST. TEMPO ELET.	Te																
Elect.time constant	[ms]	3.5	3.13	3	3	2.4	2		3.4	3.8	3.13			2.4			
COST. TEMPO MECC.	Tm																
Mech.time constant	[ms]	13	19	14	14	17	22		13	12	19			17			

* Solo per servizio intermittente - Only intermittent duty

DATI MECCANICI - Mechanical data

INERZIA ROTORE	Jm	
Rotor inertia	[Kgm ²]	0.0007
MAX ACC. TEORICA		
Max theor. Acc.	[Rad/sec ²]	6850
CARICO RADIALE MAX	RI	
Max radial load	[N]	343
CARICO ASSIALE MAX	AI	
Max axial load	[N]	103
PESO MOTORE	G	
Motor weight	[Kg]	5.3
VENTILAZIONE		NATURALE
Ventilation		T.E.N.V.
GRADO DI PROTEZIONE		
Class protection	IP	54

DATI ELETTRICI - Winding data

COST. DI TEMPO TERMICO	Tt	
Thermal time constant	[min]	35
MAX VEL. SENZA CARICO	No max	
Max no load speed	[rpm]	4000
MAX VEL. CON CARICO	N max	
Max load speed	[rpm]	3000
CLASSE D'ISOLAMENTO		
Insulation class		F
FATTORE DI SERVIZIO		
Duty cycle		S1
FATTORE DI FORMA		
Form factor	FF	1
TEMP. AMBIENTE RIF. DATI	T rif	
Room temp. data refer.	[°C]	40°

MOTORI IN CORRENTE CONTINUA

D.C. MOTORS

SERIE
Series

PENTA

5M

W	RPM
360	3000
240	2000

CARATTERISTICHE GENERALI - Performance characteristics

TIPO MOTORE	5M 30								5M 20								
Motor type	5M 30								5M 20								
POTENZA RESA Rated power	Pnom [W]	360								240							
VELOCITA' NOMINALE Rated speed	Nnom [rpm]	3000								2000							
COPPIA NOMINALE Rated torque	Cnom [Nm]	1.15								1.15							
TENSIONE NOMINALE Rated voltage	Vnom [V]	180	90	60	48	36	24*	12*	180	90	60	48	36	24	12*		
CORRENTE NOMINALE Rated current	Inom [A]	2.6	5	7.5	9.4	12.5			1.7	3.4	5	6.25	8.3	12.5			
COPPIA MASSIMA Peak torque	Cmax [Nm]	5.75	5.75	5.75	5.75	5.75			5.75	5.75	5.75	5.75	5.75	5.75			
CORRENTE MASSIMA Peak current	Imax [A]	12.6	25	37.5	47	62.5			8.5	17	25			62.5			
RESISTENZA ARMATURA Armature resistance	Rarm [Ohm]	4.05	0.9	0.52	0.35	0.25			7.2	1.84	0.9			0.25			
INDUTTANZA ARMATURA Armature inductance	La [mH]	14.3	3	1.43	1	0.56			27	6.8	3	2	1.2	0.56			
COST. TENSIONE Voltage constant	Ke [V/Krpm]		27	19.5	15.5	11.5			87	40	27			11.5			
COST. TEMPO ELET. Elect.time constant	Te [ms]		3.4	2.75	2.9	2.5			3.75	3.7	3.4			2.5			
COST. TEMPO MECC. Mech.time constant	Tm [ms]		10	12	13	14			8	10	10			14			

* Solo per servizio intermittente - Only intermittent duty

DATI MECCANICI - Mechanical data

INERZIA ROTORE Rotor inertia	Jm [Kgm ²]	0.0008
MAX ACC. TEORICA Max theor. Acc.	[Rad/sec ²]	7187
CARICO RADIALE MAX Max radial load	Rl [N]	343
CARICO ASSIALE MAX Max axial load	Al [N]	103
PESO MOTORE Motor weight	G [Kg]	6.4
VENTILAZIONE Ventilation	NATURALE T.E.N.V.	
GRADO DI PROTEZIONE Class protection	IP	54

DATI ELETTRICI - Winding data

COST. DI TEMPO TERMICO Thermal time constant	Tt [min]	45
MAX VEL. SENZA CARICO Max no load speed	No max [rpm]	4000
MAX VEL. CON CARICO Max load speed	N max [rpm]	3000
CLASSE D'ISOLAMENTO Insulation class	F	
FATTORE DI SERVIZIO Duty cycle	S1	
FATTORE DI FORMA Form factor	FF	1
TEMP. AMBIENTE RIF. DATI Room temp. data refer.	T rif [°C]	40°

MOTORI IN CORRENTE CONTINUA

D.C. MOTORS

SERIE
Series

PENTA

5L

W	RPM
500	3000
335	2000

CARATTERISTICHE GENERALI - Performance characteristics

TIPO MOTORE		5L 30						5L 20							
Motor type															
POTENZA RESA	P _{nom}														
Rated power	[W]	500						335							
VELOCITA' NOMINALE	N _{nom}														
Rated speed	[rpm]	3000						2000							
COPPIA NOMINALE	C _{nom}														
Rated torque	[Nm]	1.6						1.6							
TENSIONE NOMINALE	V _{nom}														
Rated voltage	[V]	180	90	60	48	36*	24*	12*	180	90	60	48	36	24*	12*
CORRENTE NOMINALE	I _{nom}														
Rated current	[A]	3.3	6.6	10.5	13				2.2	4.4	6.6	10			
COPPIA MASSIMA	C _{max}														
Peak torque	[Nm]	8	8	8	8				8	8	8	8			
CORRENTE MASSIMA	I _{max}														
Peak current	[A]	16.5	33	51.5	65				11	22	33				
RESISTENZA ARMATURA	R _{arm}														
Armature resistance	[Ohm]	2.62	0.86	1.42	0.16				5.4	1.1	0.86				
INDUTTANZA ARMATURA	L _a														
Armature inductance	[mH]	8.8	2.2	0.95	0.35				18.5	4.3	2.2	1.39			
COST. TENSIONE	K _e														
Voltage constant	[V/Krpm]	57	27.7	17.8	11.5				84	40	27.7	21.5			
COST. TEMPO ELET.	T _e														
Elect.time constant	[ms]	3.4	2.6		2.2				3.43	3.9	2.6				
COST. TEMPO MECC.	T _m														
Mech.time constant	[ms]	9	12		14				8	7	12				

* Solo per servizio intermittente - Only intermittent duty

DATI MECCANICI - Mechanical data

INERZIA ROTORE	J _m	
Rotor inertia	[Kgm ²]	0.001
MAX ACC. TEORICA		
Max theor. Acc.	[Rad/sec ²]	8000
CARICO RADIALE MAX	R _I	
Max radial load	[N]	343
CARICO ASSIALE MAX	A _I	
Max axial load	[N]	103
PESO MOTORE	G	
Motor weight	[Kg]	8
VENTILAZIONE		NATURALE
Ventilation		T.E.N.V.
GRADO DI PROTEZIONE		
Class protection	IP	54

DATI ELETTRICI - Winding data

COST. DI TEMPO TERMICO	T _t	
Thermal time constant	[min]	55
MAX VEL. SENZA CARICO	No max	
Max no load speed	[rpm]	4000
MAX VEL. CON CARICO	N max	
Max load speed	[rpm]	3000
CLASSE D'ISOLAMENTO		
Insulation class		F
FATTORE DI SERVIZIO		
Duty cycle		S1
FATTORE DI FORMA		
Form factor	FF	1
TEMP. AMBIENTE RIF. DATI	T _{rif}	
Room temp. data refer.	[°C]	40°

PENTA 5

MOTORI C.C.

D.C. MOTORS

DIMENSIONI (mm) DIMENSIONS (mm)

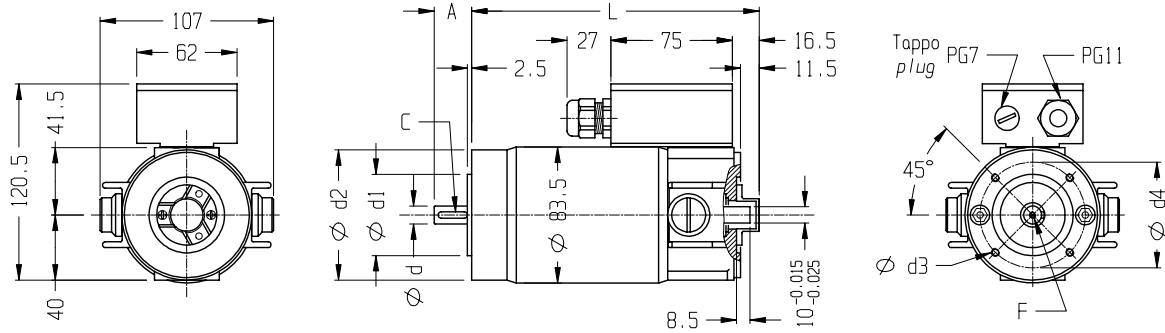

Type	X	XS		S		SL		M		L	
Size	B14/56	B14/56	B14/63	B14/56	B14/63	B14/63	B14/71	B14/63	B14/71	B14/63	B14/71
A	20	20	23	20	23	23	30	23	30	23	30
L	144.5	177.5		212.5		229		267.5		322.5	
d(h7)	9	9	11	9	11	11	14	11	14	11	14
F	-	-	M4	-	M4	M4	M5	M4	M5	M4	M5
C	3x3x15	3x3x15	4x4x18	3x3x15	4x4x18	4x4x18	5x5x25	4x4x18	5x5x25	4x4x18	5x5x25
d1(h7)	50	50	60	50	60	60	70	60	70	60	70
d2	80	80	90	80	90	90	105	90	105	90	105
d3	M5	M5	M5	M5	M5	M5	M6	M5	M6	M5	M6
d4	65	65	75	65	75	75	85	75	85	75	85

FLANGIA B5

B5 FLANGE

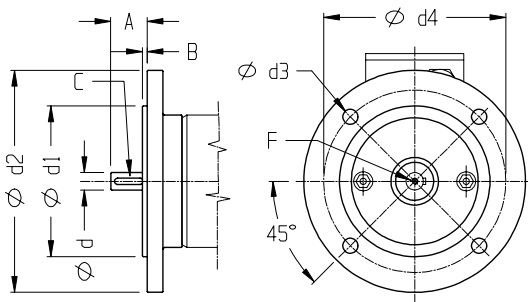

Size	A	B	C	d(h7)	d1(h7)	d2	d3	d4	F
56	20	3	3x3x15	9	80	120	8.5	100	-
63	23	3	4x4x18	11	95	140	9.5	115	M4
71	30	3.5	5x5x25	14	110	160	9.5	130	M5

FLANGIA B14

B14 FLANGE

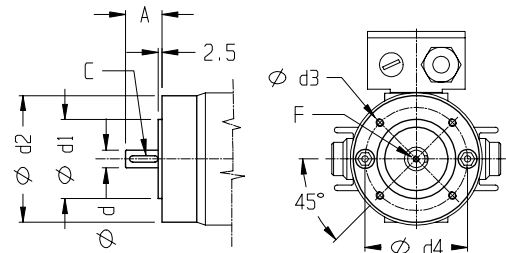

Size	A	C	d(h7)	d1(h7)	d2	d3	d4	F
56	20	3x3x15	9	50	80	M5	65	-
63	23	4x4x18	11	60	90	M5	75	M4
71	30	5x5x25	14	70	105	M6	85	M5

CONNETTORE

CONNECTOR

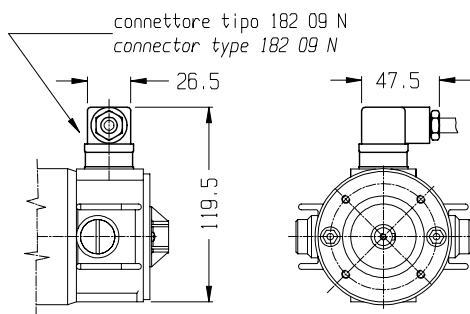

CAVO

FLYING LEADS

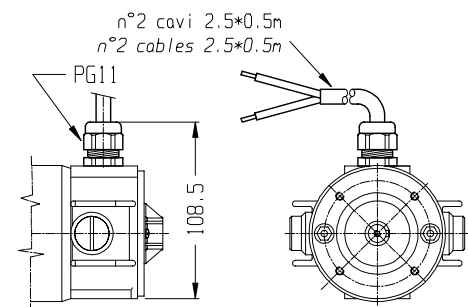

PENTA 5

MOTORI C.C.

D.C. MOTORS

OPTIONALS

FLANGIA B3-B14/56

B3-B14/56 FLANGE

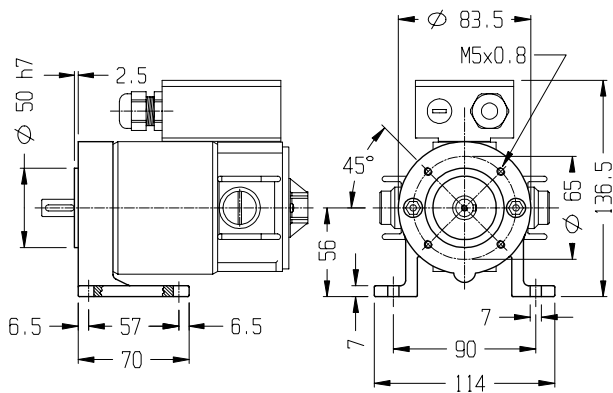

PIEDE A FASCIA

FOOT BAND TYPE

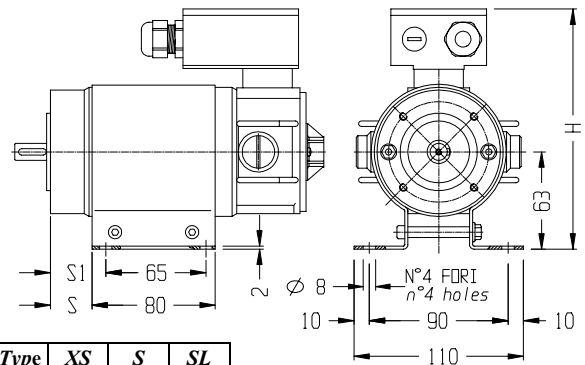

Type	XS	S	SL
H	155.5	143.5	143.5
S	27	27	27
SI	36	36	36

PASSACAVO

CABLE GLAND

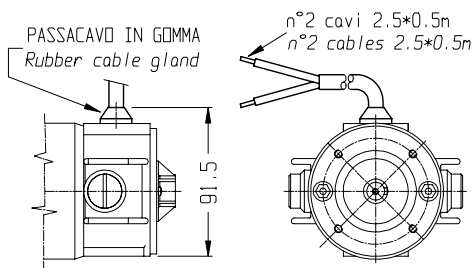

PRED. ENCODER

ENC. PREARRANGEMENT

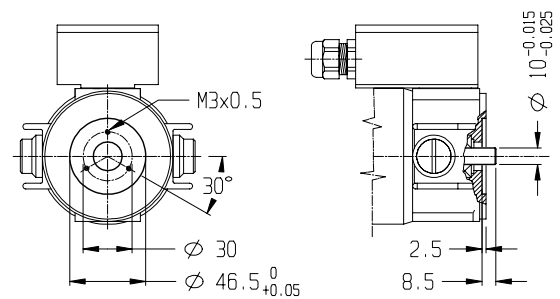

ENCODER EH53

ENCODER EH53

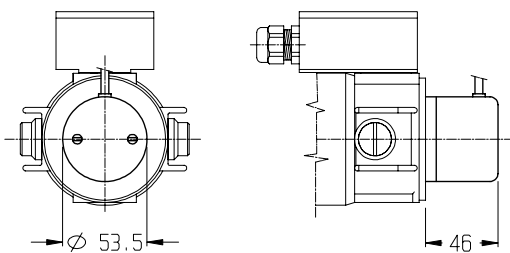

ENCODER EH38

ENCODER EH38

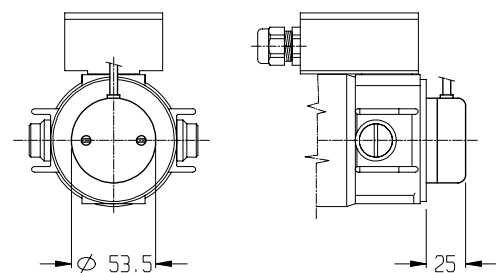

PENTA 5

MOTORI C.C.

D.C. MOTORS

OPTIONALS

DISTANZ. ENC. N°1 *ENCODER SPACER N°1*

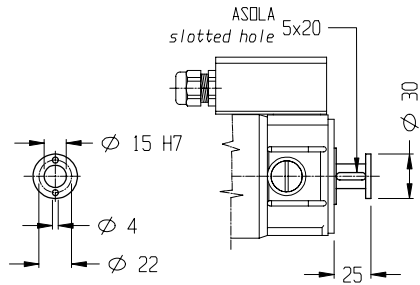

DISTANZ. ENC. N°2 *ENCODER SPACER N°2*

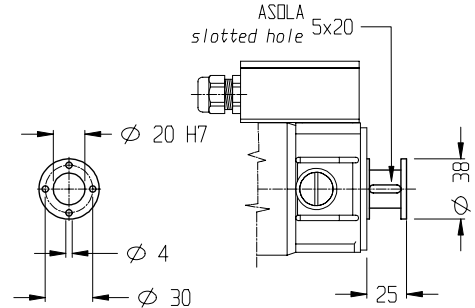

DISTANZ. ENC. N°3 *ENCODER SPACER N°3*

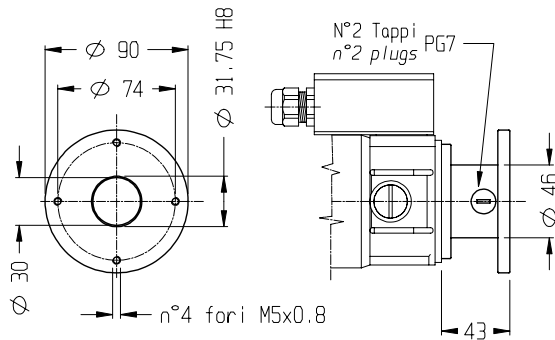

DIN. TACHIMETRICA *TACHO GENERATOR*

PREDISPOSTO ENCODER *ENCODER PREARRANGEMENT*

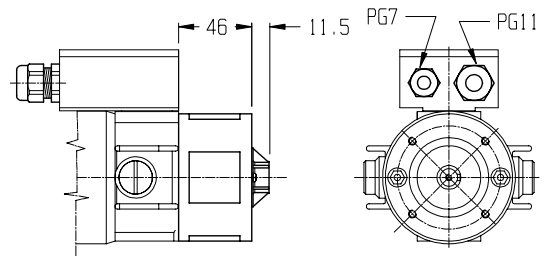

COSTANTE DI TENSIONE <i>VOLTAGE CONSTANT</i>	10±5% V/KRPM	CORRENTE NOMINALE <i>RATED CURRENT</i>	2 mA
VELOCITA' MASSIMA <i>MAX SPEED</i>	9000 RPM	CORRENTE MASSIMA <i>MAX CURRENT</i>	8 mA

FRENO 1,7 Nm

BRAKE 1,7 Nm

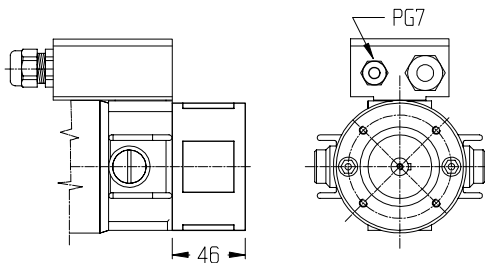

COPPIA STATICA <i>STATIC TORQUE</i>	1,7 Nm	CORRENTE <i>CURRENT</i>	0.46-0.058 A
TENSIONE DI ALIMEN. <i>POWER SUPPLY VOLTAGE</i>	24-190 V.c.c.	POTENZA ASSORBITA <i>INPUT POWER</i>	11 W

FRENO 1,7 Nm + DIN. TACHO GENERATOR + TACHIMETRICA *TACHO GENERATOR + BRAKE 1,7 Nm*

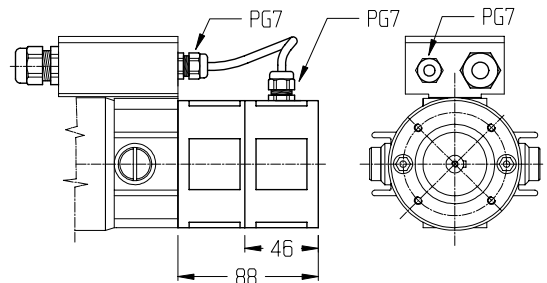

	FRENO <i>BRAKE</i>	DINAMO T. <i>TACHO G.</i>
COPPIA STATICA <i>STATIC TORQUE</i>	1,7 Nm	COSTANTE DI TENSIONE <i>VOLTAGE CONSTANT</i>
TENSIONE DI ALIMEN. <i>POWER SUPPLY VOLTAGE</i>	24-190 V.c.c.	VELOCITA' MASSIMA <i>MAX SPEED</i>
CORRENTE <i>CURRENT</i>	0.46-0.058 A	CORRENTE NOMINALE <i>RATED CURRENT</i>
POTENZA ASSORBITA <i>INPUT POWER</i>	11 W	CORRENTE MASSIMA <i>MAX CURRENT</i>

PENTA 5

OPTIONALS

FRENO 4 Nm

BRAKE 4 Nm

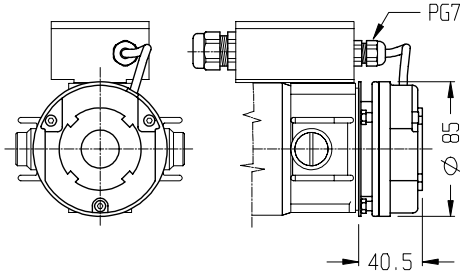

COPPIA STATICA <i>STATIC TORQUE</i>	4 Nm	CORRENTE <i>CURRENT</i>	0.83-0.109 A
TENSIONE DI ALIMEN. <i>POWER SUPPLY VOLTAGE</i>	24-190 V.c.c.	POTENZA ASSORBITA <i>INPUT POWER</i>	20 W

FRENO 4 Nm + DIN. TACHIMETRICA

TACHO GENERATOR + BRAKE 4 Nm

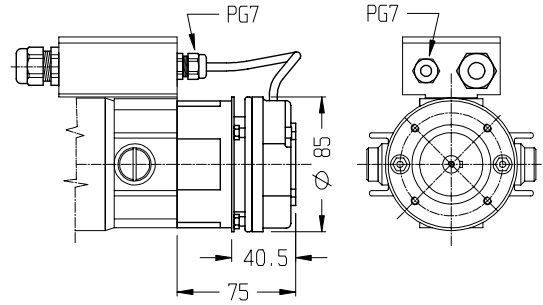

FRENO	BRAKE	DINAMO T.	TACHO G.
COPPIA STATICA <i>STATIC TORQUE</i>	4 Nm	COSTANTE DI TENSIONE <i>VOLTAGE CONSTANT</i>	10±5% V/KRPM
TENSIONE DI ALIMEN. <i>POWER SUPPLY VOLTAGE</i>	24-190 V.c.c.	VELOCITA' MASSIMA <i>MAX SPEED</i>	9000 RPM
CORRENTE <i>CURRENT</i>	0.83-0.109 A	CORRENTE NOMINALE <i>RATED CURRENT</i>	2 mA
POTENZA ASSORBITA <i>INPUT POWER</i>	20 W	CORRENTE MASSIMA <i>MAX CURRENT</i>	8 mA

MOTORI IN CORRENTE CONTINUA

D.C. MOTORS

SERIE
Series

PENTA

5XA

W	RPM
150	3000
100	2000

CARATTERISTICHE GENERALI - Performance characteristics

TIPO MOTORE		5XA 30								5XA 20							
MOTOR type																	
POTENZA RESA	Pnom																
Rated power	[W]	150								100							
VELOCITA' NOMINALE	Nnom																
Rated speed	[rpm]	3000								2000							
COPPIA NOMINALE	Cnom																
Rated torque	[Nm]	0.48								0.48							
TENSIONE NOMINALE	Vnom																
Rated voltage	[V]	180	90	60	48	36	24	12	180	90	60	48	36	24	12		
CORRENTE NOMINALE	Inom																
Rated current	[A]	1.1		3.3	4	5.54	8.33	16	0.74	1.54	2.2	2.8		5.5	11		
COPPIA MASSIMA	Cmax																
Peak torque	[Nm]	2.4		2.4	2.4	2.4	2.4	2.4	2.4	2.4	2.4	2.4		2.4	2.4		
CORRENTE MASSIMA	Imax																
Peak current	[A]	5.5		16.7	20	27.7	41.7	80	3.7	7.7	11	14		27.5	55		
RESISTENZA ARMATURA	Rarm																
Armature resistance	[Ohm]	16.1		1.8	1.1	0.74	0.45	0.1	44.1	10.9	4	2.7		0.53	0.17		
INDUTTANZA ARMATURA	La																
Armature inductance	[mH]	51.5		5.4	3	1.8	0.9	0.18	145.5	35.4	12.6	8		1.32	0.34		
COST. TENSIONE	Ke																
Voltage constant	[V/Krpm]	50		16.5	13.5	10	6.5	3.5	70	35.5	24	19		8	4.8		
COST. TEMPO ELET.	Te																
Elect.time constant	[ms]	3.2		3	2.7	2.4	2.2	1.8	3.3	3.25	3.15	3		2.5	2		
COST. TEMPO MECC.	Tm																
Mech.time constant	[ms]	13		13	12	14	19	16	18	17	14	15		13	12		

* Solo per servizio intermittente - Only intermittent duty

DATI MECCANICI - Mechanical data

INERZIA ROTORE	Jm	
Rotor inertia	[Kgm ²]	0.00018
MAX ACC. TEORICA		
Max theor. Acc.	[Rad/sec ²]	13300
CARICO RADIALE MAX	RI	
Max radial load	[N]	294
CARICO ASSIALE MAX	AI	
Max axial load	[N]	88
PESO MOTORE	G	
Motor weight	[Kg]	3.6
VENTILAZIONE	AUTOVENTILATO	
Ventilation	T.E.N.V.	
GRADO DI PROTEZIONE		
Class protection	IP	54

DATI ELETTRICI - Winding data

COST. DI TEMPO TERMICO	Tt	
Thermal time constant	[min]	30
MAX VEL. SENZA CARICO	No max	
Max no load speed	[rpm]	4000
MAX VEL. CON CARICO	N max	
Max load speed	[rpm]	3000
CLASSE D'ISOLAMENTO		
Insulation class		F
FATTORE DI SERVIZIO		
Duty cycle		S1
FATTORE DI FORMA		
Form factor	FF	1
TEMP. AMBIENTE RIF. DATI	T rif	
Room temp. data refer.	[°C]	40°

MOTORI IN CORRENTE CONTINUA

D.C. MOTORS

SERIE
Series

PENTA

5XSA

W	RPM
235	3000
155	2000

CARATTERISTICHE GENERALI - Performance characteristics

TIPO MOTORE Motor type		5XSA 30							5XSA 20						
POTENZA RESA Rated power	Pnom [W]	235							155						
VELOCITA' NOMINALE Rated speed	Nnom [rpm]	3000							2000						
COPPIA NOMINALE Rated torque	Cnom [Nm]	0.75							0.75						
TENSIONE NOMINALE Rated voltage	Vnom [V]	180	90	60	48	36	24	12*	180	90	60	48	36	24	12*
CORRENTE NOMINALE Rated current	Inom [A]	1.7	3.4	5	6.25	8.3	12.5		1.14	2.28	3.4	4.3	5.7	8.54	
COPPIA MASSIMA Peak torque	Cmax [Nm]	3.75	3.75	3.75	3.75	3.75	3.75		3.75	3.75	3.75	3.75	3.75	3.75	
CORRENTE MASSIMA Peak current	Imax [A]	8.5		25	31	41.5	62.5		5.7	11.4	17	21.5		42.7	
RESISTENZA ARMATURA Armature resistance	Rarm [Ohm]	13.65		1.5	0.9	0.58	0.38		30.6	7.6	3.3	2.25		0.41	
INDUTTANZA ARMATURA Armature inductance	La [mH]	47	11.5	4.5	2.5	1.6	0.825		107	26	10.4	6.45	4	1.45	
COST. TENSIONE Voltage constant	Ke [V/Krpm]	50		16.5	13.5	10	6.5		70	35.5	24	19		8	
COST. TEMPO ELET. Elect.time constant	Te [ms]	3.45		3	2.8	2.75	2.17		3.5	3.4	3.12	2.9		2.3	
COST. TEMPO MECC. Mech.time constant	Tm [ms]	18		18	16	21	28		20	20	19	20		21	

* Solo per servizio intermittente - Only intermittent duty

DATI MECCANICI - Mechanical data

INERZIA ROTORE Rotor inertia	Jm [Kgm ²]	0.0003
MAX ACC. TEORICA Max theor. Acc.	[Rad/sec ²]	12500
CARICO RADIALE MAX Max radial load	RI [N]	294
CARICO ASSIALE MAX Max axial load	AI [N]	88
PESO MOTORE Motor weight	G [Kg]	4.2
VENTILAZIONE Ventilation	AUTOVENTILATO T.E.N.V.	
GRADO DI PROTEZIONE Class protection	IP	54

DATI ELETTRICI - Winding data

COST. DI TEMPO TERMICO Thermal time constant	Tt [min]	35
MAX VEL. SENZA CARICO Max no load speed	No max [rpm]	4000
MAX VEL. CON CARICO Max load speed	N max [rpm]	3000
CLASSE D'ISOLAMENTO Insulation class		F
FATTORE DI SERVIZIO Duty cycle		S1
FATTORE DI FORMA Form factor	FF	1
TEMP. AMBIENTE RIF. DATI Room temp. data refer.	T rif [°C]	40°

MOTORI IN CORRENTE CONTINUA

D.C. MOTORS

SERIE
Series

PENTA

5SA

W	RPM
300	3000
200	2000

CARATTERISTICHE GENERALI - Performance characteristics

TIPO MOTORE		5SA 30								5SA 20							
Motor type																	
POTENZA RESA	P _{nom}																
Rated power	[W]	300								200							
VELOCITA' NOMINALE	N _{nom}																
Rated speed	[rpm]	3000								2000							
COPPIA NOMINALE	C _{nom}																
Rated torque	[Nm]	0.96								0.96							
TENSIONE NOMINALE	V _{nom}																
Rated voltage	[V]	180	90	60	48	36	24	12*	180	90	60	48	36	24	12*		
CORRENTE NOMINALE	I _{nom}																
Rated current	[A]	2.1	4.2	6.3	7.8	10.4	15.6		1.4	2.8	4.2	5.2	7	10.4			
COPPIA MASSIMA	C _{max}																
Peak torque	[Nm]	4.8	4.8	4.8	4.8	4.8	4.8		4.8	4.8	4.8	4.8	4.8	4.8			
CORRENTE MASSIMA	I _{max}																
Peak current	[A]	10.5		31.5	39	52	78		7	14	21	26		52			
RESISTENZA ARMATURA	R _{arm}																
Armature resistance	[Ohm]	5.9		0.76	0.49	0.32	0.18		11.7	2.9	1.6	1.1		0.235			
INDUTTANZA ARMATURA	L _a																
Armature inductance	[mH]	19		2.2	1.32	0.8	0.38		36	9	4.9	3		0.52			
COST. TENSIONE	K _e																
Voltage constant	[V/Krpm]	50		16.5	13.5	10	7		74	37	24	19		8.5			
COST. TEMPO ELET.	T _e																
Elect.time constant	[ms]	3.3		2.9	2.7	2.5	2.1		3.1	3.1	3.1	2.7		2.2			
COST. TEMPO MECC.	T _m																
Mech.time constant	[ms]	15		18	17	21	24		14	14	15	20		21			

* Solo per servizio intermittente - Only intermittent duty

DATI MECCANICI - Mechanical data

INERZIA ROTORE	J _m	
Rotor inertia	[Kgm ²]	0.0006
MAX ACC. TEORICA		
Max theor. Acc.	[Rad/sec ²]	8000
CARICO RADIALE MAX	R _I	
Max radial load	[N]	294
CARICO ASSIALE MAX	A _I	
Max axial load	[N]	88
PESO MOTORE	G	
Motor weight	[Kg]	5.5
VENTILAZIONE	AUTOVENTILATO	
Ventilation	T.E.N.V.	
GRADO DI PROTEZIONE		
Class protection	IP	54

DATI ELETTRICI - Winding data

COST. DI TEMPO TERMICO	T _t	
Thermal time constant	[min]	40
MAX VEL. SENZA CARICO	No max	
Max no load speed	[rpm]	4000
MAX VEL. CON CARICO	N max	
Max load speed	[rpm]	3000
CLASSE D'ISOLAMENTO		
Insulation class		F
FATTORE DI SERVIZIO		
Duty cycle		S1
FATTORE DI FORMA		
Form factor	FF	1
TEMP. AMBIENTE RIF. DATI	T _{rif}	
Room temp. data refer.	[°C]	40°

MOTORI IN CORRENTE CONTINUA

D.C. MOTORS

SERIE
Series

PENTA

5SLA

W	RPM
440	3000
290	2000

CARATTERISTICHE GENERALI - Performance characteristics

TIPO MOTORE		5SLA 30							5SLA 20						
Motor type															
POTENZA RESA	P _{nom}														
Rated power	[W]	440							290						
VELOCITA' NOMINALE	N _{nom}														
Rated speed	[rpm]	3000							2000						
COPPIA NOMINALE	C _{nom}														
Rated torque	[Nm]	1.4							1.4						
TENSIONE NOMINALE	V _{nom}														
Rated voltage	[V]	180	90	60	48	36	24*	12*	180	90	60	48	36	24	12*
CORRENTE NOMINALE	I _{nom}														
Rated current	[A]	3	6	9	11.3	15			2	4	6	7.5	10	15	
COPPIA MASSIMA	C _{max}														
Peak torque	[Nm]	7	7	7	7	7			7	7	7	7	7	7	
CORRENTE MASSIMA	I _{max}														
Peak current	[A]	15	30	45	56.5	75			10	20	30	37.5	50	75	
RESISTENZA ARMATURA	R _{arm}														
Armature resistance	[Ohm]	4.86	1.37	0.54	0.45	0.27			11	3.05	1.37	0.88	0.45	0.25	
INDUTTANZA ARMATURA	L _a														
Armature inductance	[mH]	17	4.45	1.84	1.4	0.62			37.8	10.3	4.45	2.5	1.4	0.57	
COST. TENSIONE	K _e														
Voltage constant	[V/Krpm]	53	26	17	14.5	10.5			78	39	26	20.5	14.5	9	
COST. TEMPO ELET.	T _e														
Elect.time constant	[ms]	3.5	3.3	3.4	3.1	2.3			3.45	3.4	3.3	2.84	3.1	2.3	
COST. TEMPO MECC.	T _m														
Mech.time constant	[ms]	13	14	14	16	18			14	15	14	15	16	25	

* Solo per servizio intermittente - Only intermittent duty

DATI MECCANICI - Mechanical data

INERZIA ROTORE	J _m	
Rotor inertia	[Kg ^m ²]	0.0007
MAX ACC. TEORICA		
Max theor. Acc.	[Rad/sec ²]	10000
CARICO RADIALE MAX	R _I	
Max radial load	[N]	343
CARICO ASSIALE MAX	A _I	
Max axial load	[N]	103
PESO MOTORE	G	
Motor weight	[Kg]	6.25
VENTILAZIONE	AUTOVENTILATO	
Ventilation	T.E.N.V.	
GRADO DI PROTEZIONE		
Class protection	IP	54

DATI ELETTRICI - Winding data

COST. DI TEMPO TERMICO	T _t	
Thermal time constant	[min]	40
MAX VEL. SENZA CARICO	No max	
Max no load speed	[rpm]	4000
MAX VEL. CON CARICO	N max	
Max load speed	[rpm]	3000
CLASSE D'ISOLAMENTO		
Insulation class		F
FATTORE DI SERVIZIO		
Duty cycle		S1
FATTORE DI FORMA		
Form factor	FF	1
TEMP. AMBIENTE RIF. DATI	T _{rif}	
Room temp. data refer.	[°C]	40°

MOTORI IN CORRENTE CONTINUA

D.C. MOTORS

SERIE
Series

PENTA

5MA

W	RPM
565	3000
375	2000

CARATTERISTICHE GENERALI - Performance characteristics

TIPO MOTORE	5MA 30								5MA 20									
Motor type																		
POTENZA RESA	Pnom																	
Rated power	[W]		565								375							
VELOCITA' NOMINALE	Nnom																	
Rated speed	[rpm]		3000								2000							
COPPIA NOMINALE	Cnom																	
Rated torque	[Nm]		1.8								1.8							
TENSIONE NOMINALE	Vnom																	
Rated voltage	[V]		180	90	60	48	36*	24*	12*	180	90	60	48	36	24*	12*		
CORRENTE NOMINALE	Inom																	
Rated current	[A]		3.7	7.4	11	13.8				2.5	5	7.4	9.3	13.8				
COPPIA MASSIMA	Cmax																	
Peak torque	[Nm]		9	9	9	9				9	9	9	9	9				
CORRENTE MASSIMA	Imax																	
Peak current	[A]		18.5	37	55	69				12.5	25	37	46.5					
RESISTENZA ARMATURA	Rarm																	
Armature resistance	[Ohm]		3.65	0.93	0.49	0.33				6.8	2.2	0.93	0.55					
INDUTTANZA ARMATURA	La																	
Armature inductance	[mH]		12	2.8	1.6	0.85				23	7	2.8	1.5	1.08				
COST. TENSIONE	Ke																	
Voltage constant	[V/Krpm]		54.5	26	18	14.5				82	41.5	26	22	16				
COST. TEMPO ELET.	Te																	
Elect.time constant	[ms]		3.3	3	3.2	2.6				3.4	3.2	3	2.7					
COST. TEMPO MECC.	Tm																	
Mech.time constant	[ms]		11	12	13	13				9	11	12	10					

* Solo per servizio intermittente - Only intermittent duty

DATI MECCANICI - Mechanical data

INERZIA ROTORE	Jm	
Rotor inertia	[Kgm ²]	0.0008
MAX ACC. TEORICA		
Max theor. Acc.	[Rad/sec ²]	11250
CARICO RADIALE MAX	RI	
Max radial load	[N]	343
CARICO ASSIALE MAX	AI	
Max axial load	[N]	103
PESO MOTORE	G	
Motor weight	[Kg]	7.5
VENTILAZIONE	AUTOVENTILATO	
Ventilation	T.E.N.V.	
GRADO DI PROTEZIONE		
Class protection	IP	54

DATI ELETTRICI - Winding data

COST. DI TEMPO TERMICO	Tt	
Thermal time constant	[min]	40
MAX VEL. SENZA CARICO	No max	
Max no load speed	[rpm]	4000
MAX VEL. CON CARICO	N max	
Max load speed	[rpm]	3000
CLASSE D'ISOLAMENTO		
Insulation class	F	
FATTORE DI SERVIZIO		
Duty cycle	S1	
FATTORE DI FORMA		
Form factor	FF	1
TEMP. AMBIENTE RIF. DATI	T rif	
Room temp. data refer.	[°C]	40°

PENTA5A

MOTORI C.C.

D.C. MOTORS

DIMENSIONI (mm) DIMENSIONS (mm)

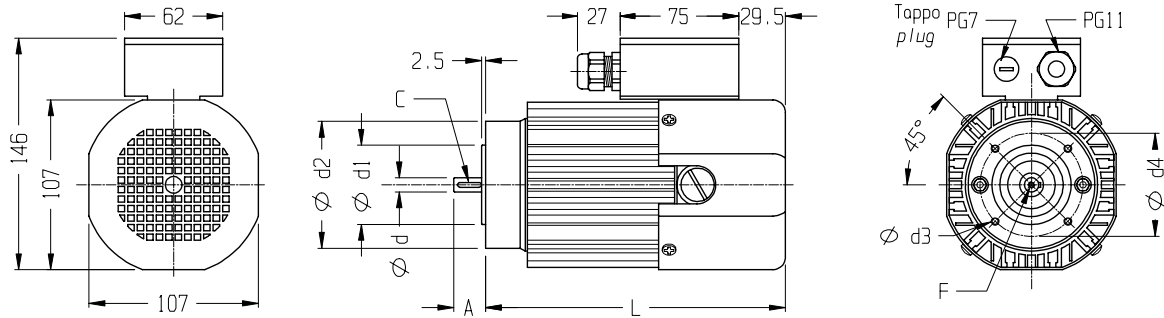

Type	X	XS		S		SL		M	
Size	B14/56	B14/56	B14/63	B14/56	B14/63	B14/63	B14/71	B14/63	B14/71
A	20	20	23	20	23	23	30	23	30
L	156.5	189.5		224.5		241		279.5	
d(h7)	9	9	11	9	11	11	14	11	14
F	-	-	M4	-	M4	M4	M5	M4	M5
C	3x3x15	3x3x15	4x4x18	3x3x15	4x4x18	4x4x18	5x5x25	4x4x18	5x5x25
d1(h7)	50	50	60	50	60	60	70	60	70
d2	80	80	90	80	90	90	105	90	105
d3	M5	M5	M5	M5	M5	M5	M6	M5	M6
d4	65	65	75	65	75	75	85	75	85

FLANGIA B5

B5 FLANGE

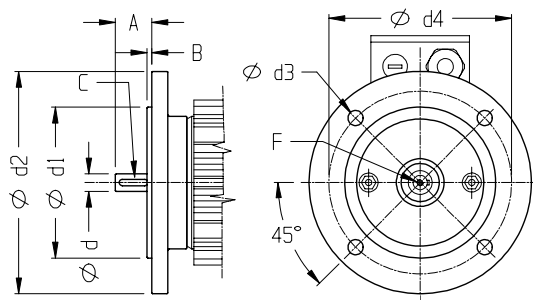

Size	A	B	C	d(h7)	d1(h7)	d2	d3	d4	F
56	20	3	3x3x15	9	80	120	8.5	100	-
63	23	3	4x4x18	11	95	140	9.5	115	M4
71	30	3.5	5x5x25	14	110	160	9.5	130	M5

FLANGIA B14

B14 FLANGE

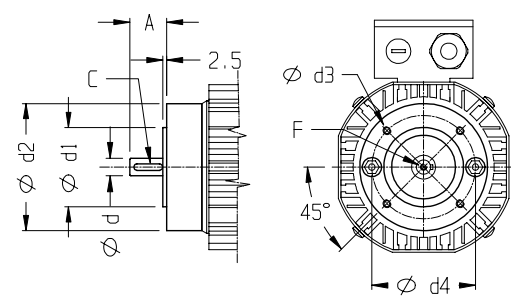

Size	A	C	d(h7)	d1(h7)	d2	d3	d4	F
56	20	3x3x15	9	50	80	M5	65	-
63	23	4x4x18	11	60	90	M5	75	M4
71	30	5x5x25	14	70	105	M6	85	M5

CAVO

FLYING LEADS

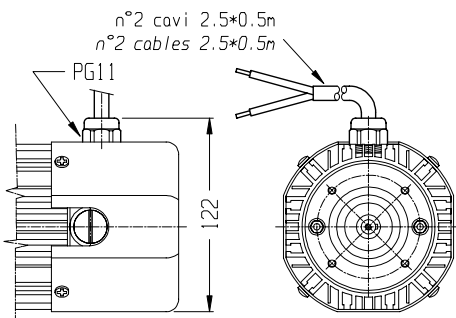

CONNETTORE

CONNECTOR

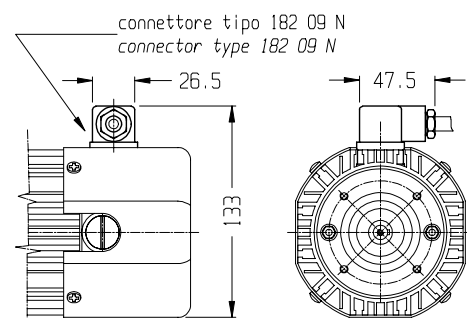

PENTA 5A

OPTIONALS

PIEDE B3

B3 FOOT

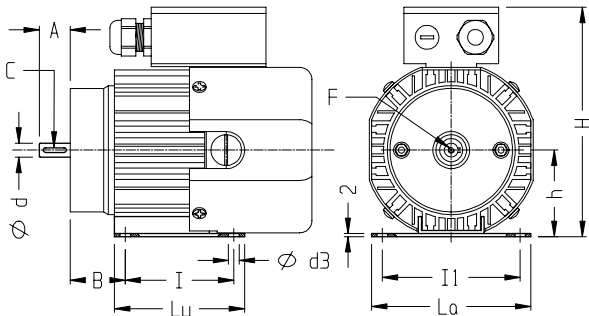

Type	XS			S		SL			M	
Size	B3/56	B3/56	B3/63	B3/56	B3/63	B3/63	B3/71	B3/63	B3/71	
A	20	20	23	20	23	23	30	23	30	
d(h7)	9	9	11	9	11	11	14	11	14	
Lu	85	85	95	85	95	95	104	95	104	
La	104	104	114	104	114	114	126	114	126	
F	-	-	M4	-	M4	M4	M5	M4	M5	
C	3x3x1	3x3x1	4x4x1	3x3x1	4x4x1	4x4x1	5x5x2	4x4x1	5x5x2	
B	36	36	40	36	40	40	45	40	45	
I	71	71	80	71	80	80	90	80	90	
II	90	90	100	90	100	100	112	100	112	
H	148.5	148.5	155.5	148.5	155.5	155.5	163.5	155.5	163.5	
h	56	56	63	56	63	63	71	63	71	
d3	7	7	9	7	9	9	9	9	9	

FLANGIA B3

B3 FLANGE

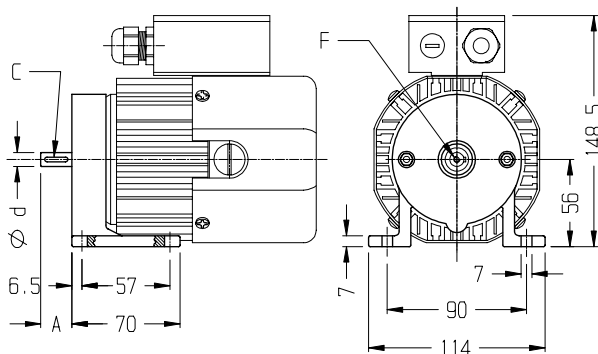

Type	X	XS		S		SL		M	
A	20	20	23	20	23	23	30	23	30
d(h7)	9	9	11	9	11	11	14	11	14
F	-	-	M4	-	M4	M4	M5	M4	M5
C	3x3x1	3x3x1	4x4x1	3x3x1	4x4x1	4x4x1	5x5x2	4x4x1	5x5x2

DIN. TACHIMETRICA

TACHO GENERATOR

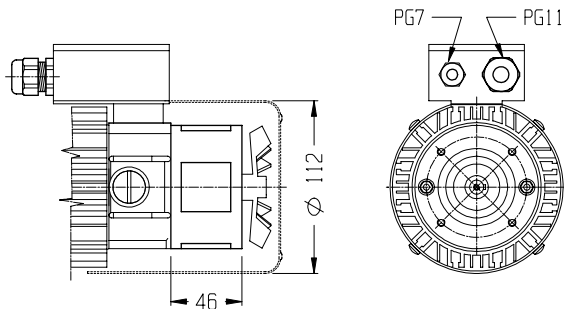

LA LUNGHEZZA TOTALE DEL MOTORE AUMENTA DI 42 mm
THE TOTAL LENGTH OF THE MOTOR INCREASES OF 42 mm

COSTANTE DI TENSIONE VOLTAGE CONSTANT	10±5% V/KRPM	CORRENTE NOMINALE RATED CURRENT	2 mA
VELOCITA' MASSIMA MAX SPEED	9000 RPM	CORRENTE MASSIMA MAX CURRENT	8 mA

FRENO 1,7 Nm

BRAKE 1,7 Nm

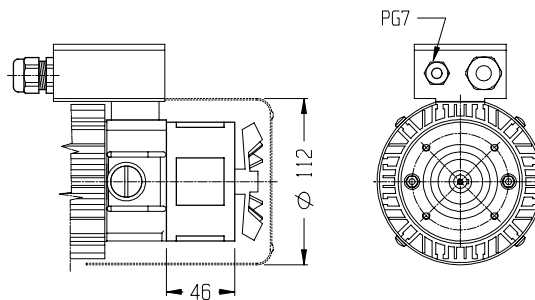

LA LUNGHEZZA TOTALE DEL MOTORE AUMENTA DI 42 mm
THE TOTAL LENGTH OF THE MOTOR INCREASES OF 42 mm

COPPIA STATICA STATIC TORQUE	1,7 Nm	CORRENTE CURRENT	0.46-0.058 A
TENSIONE DI ALIMEN. POWER SUPPLY VOLTAGE	24-190 V.c.c.	POTENZA ASSORBITA INPUT POWER	11 W

FRENO 4 Nm

BRAKE 4 Nm

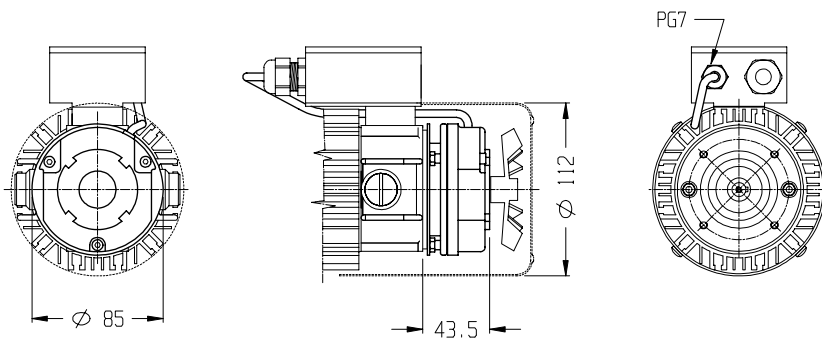

LA LUNGHEZZA TOTALE DEL MOTORE AUMENTA DI 42 mm
THE TOTAL LENGTH OF THE MOTOR INCREASES OF 42 mm

COPPIA STATICA STATIC TORQUE	4 Nm
TENSIONE DI ALIMEN. POWER SUPPLY VOLTAGE	24-190 V.c.c.
CORRENTE CURRENT	0.83-0.109 A
POTENZA ASSORBITA INPUT POWER	20 W

MOTORI IN CORRENTE CONTINUA

D.C. MOTORS

SERIE
Series

PENTA

7SA

W	RPM
750	3000
500	2000

CARATTERISTICHE GENERALI - Performance characteristics

TIPO MOTORE	7SA 30							7SA 20							
Motor type															
POTENZA RESA <i>Rated power</i>	Pnom [W]	750							500						
VELOCITA' NOMINALE <i>Rated speed</i>	Nnom [rpm]	3000							2000						
COPPIA NOMINALE <i>Rated torque</i>	Cnom [Nm]	2.4							2.4						
TENSIONE NOMINALE <i>Rated voltage</i>	Vnom [V]	180	90	60*	48*	36*	24*	180	90	60	48	36*	24*	12*	
CORRENTE NOMINALE <i>Rated current</i>	Inom [A]	5.7	10.6					3.55	7	14	14				
COPPIA MASSIMA <i>Peak torque</i>	Cmax [Nm]	12	12					12	12	12	13.25				
CORRENTE MASSIMA <i>Peak current</i>	Imax [A]	28.5	53					17.75	35	10.7					
RESISTENZA ARMATURA <i>Armature resistance</i>	Rarm [Ohm]	2.35	0.71					5.55	1.44						
INDUTTANZA ARMATURA <i>Armature inductance</i>	La [mH]	13.9	4.6					35.4	9	2.77	1.61				
COST. TENSIONE <i>Voltage constant</i>	Ke [V/Krpm]	58	29.5					87	44	26.1	20.3				
COST. TEMPO ELET. <i>Elect.time constant</i>	Te [ms]	5.9	6.5					6.4	6.3						
COST. TEMPO MECC. <i>Mech.time constant</i>	Tm [ms]	14	16					14	14						

* Solo per servizio intermittente - Only intermittent duty

DATI MECCANICI - Mechanical data

INERZIA ROTORE <i>Rotor inertia</i>	Jm [Kgm ²]	0.0018
MAX ACC. TEORICA <i>Max theor. Acc.</i>	[Rad/sec ²]	6600
CARICO RADIALE MAX <i>Max radial load</i>	Rl [N]	588
CARICO ASSIALE MAX <i>Max axial load</i>	Al [N]	176
PESO MOTORE <i>Motor weight</i>	G [Kg]	9.4
VENTILAZIONE <i>Ventilation</i>	AUTOVENTILATO T.E.N.V.	
GRADO DI PROTEZIONE <i>Class protection</i>	IP	54

DATI ELETTRICI - Winding data

COST. DI TEMPO TERMICO <i>Thermal time constant</i>	Tt [min]	45
MAX VEL. SENZA CARICO <i>Max no load speed</i>	No max [rpm]	4000
MAX VEL. CON CARICO <i>Max load speed</i>	N max [rpm]	3000
CLASSE D'ISOLAMENTO <i>Insulation class</i>		F
FATTORE DI SERVIZIO <i>Duty cycle</i>		S1
FATTORE DI FORMA <i>Form factor</i>	FF	1
TEMP. AMBIENTE RIF. DATI <i>Room temp. data refer.</i>	T rif [°C]	40°

MOTORI IN CORRENTE CONTINUA

D.C. MOTORS

SERIE
Series

PENTA

7MA

W	RPM
1100	3000
750	2000

CARATTERISTICHE GENERALI - Performance characteristics

TIPO MOTORE	7MA 30						7MA 20						
Motor type	7MA 30						7MA 20						
POTENZA RESA <i>Rated power</i>	Pnom [W]	1100						750					
VELOCITA' NOMINALE <i>Rated speed</i>	Nnom [rpm]	3000						2000					
COPPIA NOMINALE <i>Rated torque</i>	Cnom [Nm]	3.5						3.5					
TENSIONE NOMINALE <i>Rated voltage</i>	Vnom [V]	180	90	60	48*	36*	180	90	60	48	36*	24*	
CORRENTE NOMINALE <i>Rated current</i>	Inom [A]	7.3	14.6	22.9			5.5	11	16.5	23			
COPPIA MASSIMA <i>Peak torque</i>	Cmax [Nm]	17.5	17.5	17.5			17.5	17.5	17.5	17.5			
CORRENTE MASSIMA <i>Peak current</i>	Imax [A]	36.5	73	114.5			27.5	55	114				
RESISTENZA ARMATURA <i>Armature resistance</i>	Rarm [Ohm]	0.85	0.26	0.30			1.51	0.45	0.5	0.22			
INDUTTANZA ARMATURA <i>Armature inductance</i>	La [mH]	3.15	0.95	0.28			6.8	1.65	1.6	0.22			
COST. TENSIONE <i>Voltage constant</i>	Ke [V/Krpm]	57.7	30	19.2			84	40	44	19.5			
COST. TEMPO ELET. <i>Elect.time constant</i>	Te [ms]	3.7	4.3				4.6	3.7					
COST. TEMPO MECC. <i>Mech.time constant</i>	Tm [ms]	8	7				6	9					

* Solo per servizio intermittente - Only intermittent duty

DATI MECCANICI - Mechanical data

INERZIA ROTORE <i>Rotor inertia</i>	Jm [Kgm ²]	0.0028
MAX ACC. TEORICA <i>Max theor. Acc.</i>	[Rad/sec ²]	6250
CARICO RADIALE MAX <i>Max radial load</i>	Rl [N]	588
CARICO ASSIALE MAX <i>Max axial load</i>	Al [N]	176
PESO MOTORE <i>Motor weight</i>	G [Kg]	13.6
VENTILAZIONE <i>Ventilation</i>	AUTOVENTILATO T.E.N.V.	
GRADO DI PROTEZIONE <i>Class protection</i>	IP	54

DATI ELETTRICI - Winding data

COST. DI TEMPO TERMICO <i>Thermal time constant</i>	Tt [min]	55
MAX VEL. SENZA CARICO <i>Max no load speed</i>	No max [rpm]	4000
MAX VEL. CON CARICO <i>Max load speed</i>	N max [rpm]	3000
CLASSE D'ISOLAMENTO <i>Insulation class</i>		F
FATTORE DI SERVIZIO <i>Duty cycle</i>		S1
FATTORE DI FORMA <i>Form factor</i>	FF	1
TEMP. AMBIENTE RIF. DATI <i>Room temp. data refer.</i>	T rif [°C]	40°

MOTORI IN CORRENTE CONTINUA

D.C. MOTORS

SERIE
Series

PENTA

7LA

W	RPM
1500	3000
1100	2000

CARATTERISTICHE GENERALI - Performance characteristics

TIPO MOTORE	7LA 30							7LA 20								
Motor type																
POTENZA RESA	Pnom															
Rated power	[W]		1500							1100						
VELOCITA' NOMINALE	Nnom															
Rated speed	[rpm]		3000							2000						
COPPIA NOMINALE	Cnom															
Rated torque	[Nm]		4.8							4.8						
TENSIONE NOMINALE	Vnom															
Rated voltage	[V]		180	110	90	60*	48*	36*	180	110	90*	60*	48*	36*	24*	
CORRENTE NOMINALE	Inom															
Rated current	[A]		9.8	15.5	19.6					6.8	11					
COPPIA MASSIMA	Cmax															
Peak torque	[Nm]		24	24	24					24	24					
CORRENTE MASSIMA	Imax															
Peak current	[A]		49	77.5	98.1					34	55					
RESISTENZA ARMATURA	Rarm															
Armature resistance	[Ohm]		0.42	0.22	0.3					1.05	0.45					
INDUTTANZA ARMATURA	La															
Armature inductance	[mH]		1.72	0.73	0.47					4.2	1.65					
COST. TENSIONE	Ke															
Voltage constant	[V/Krpm]		57	35	28.5					84	53.5					
COST. TEMPO ELET.	Te															
Elect.time constant	[ms]		4.1	4.1					4.15	4.1						
COST. TEMPO MECC.	Tm															
Mech.time constant	[ms]		7	8					8	7						

* Solo per servizio intermittente - Only intermittent duty

DATI MECCANICI - Mechanical data

INERZIA ROTORE	Jm	
Rotor inertia	[Kgm ²]	0.0051
MAX ACC. TEORICA		
Max theor. Acc.	[Rad/sec ²]	4705
CARICO RADIALE MAX	RI	
Max radial load	[N]	588
CARICO ASSIALE MAX	AI	
Max axial load	[N]	176
PESO MOTORE	G	
Motor weight	[Kg]	17
VENTILAZIONE	AUTOVENTILATO	
Ventilation	T.E.N.V.	
GRADO DI PROTEZIONE		
Class protection	IP	54

DATI ELETTRICI - Winding data

COST. DI TEMPO TERMICO	Tt	
Thermal time constant	[min]	65
MAX VEL. SENZA CARICO	No max	
Max no load speed	[rpm]	4000
MAX VEL. CON CARICO	N max	
Max load speed	[rpm]	3000
CLASSE D'ISOLAMENTO		
Insulation class	F	
FATTORE DI SERVIZIO		
Duty cycle	S1	
FATTORE DI FORMA		
Form factor	FF	1
TEMP. AMBIENTE RIF. DATI	T rif	
Room temp. data refer.	[°C]	40°

PENTA7A

MOTORI C.C.

D.C. MOTORS

DIMENSIONI (mm) DIMENSIONS (mm)

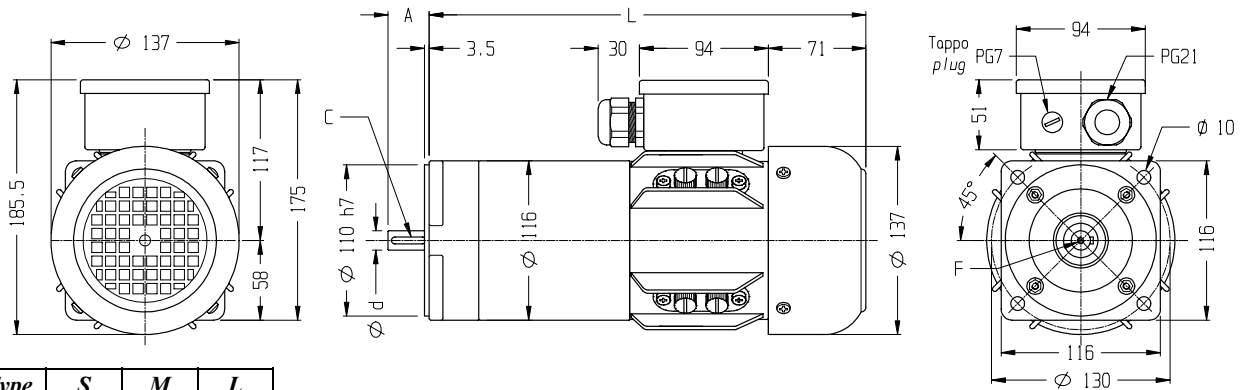

Type	S	M	L
A		40	
L	318	390	462
d(h7)	19		
F	M6		
C	6x6x30		

FLANGIA B5

B5 FLANGE

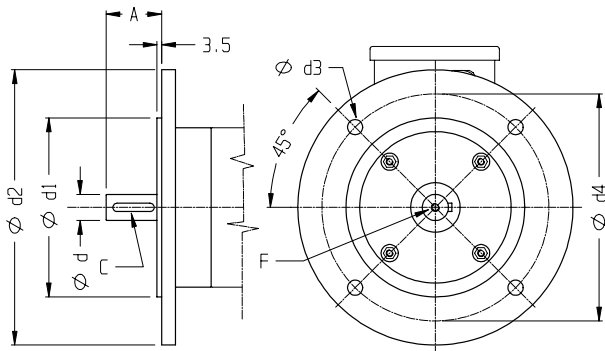

Size	A	C	d(h7)	d1(h7)	d2	d3	d4	F
71	30	5x5x25	14	110	160	9.5	130	M5
80	40	6x6x30	19	130	200	11	165	M6

FLANGIA B14

B14 FLANGE

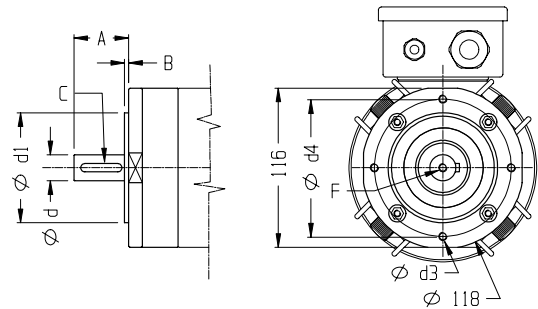

Size	A	B	C	d(h7)	d1(h7)	d3	d4	F
71	30	2.5	5x5x25	14	70	M6	85	M5
80	40	3	6x6x30	19	80	M6	100	M6

PENTA 7A

MOTORI C.C.

D.C. MOTORS

OPTIONALS

PIEDE A FASCIA

FOOT BAND TYPE

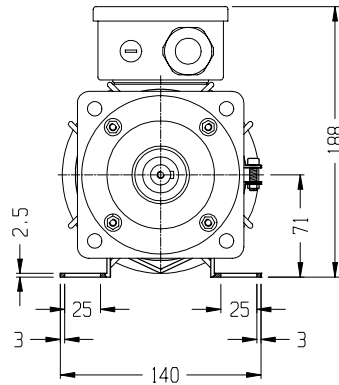
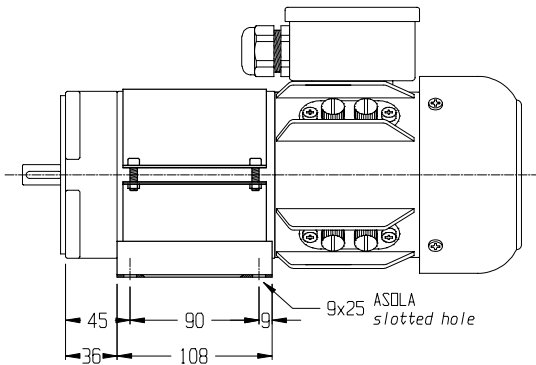

SOLO TAGLIA S
ONLY TYPE S

PIEDE A FASCIA

FOOT BAND TYPE

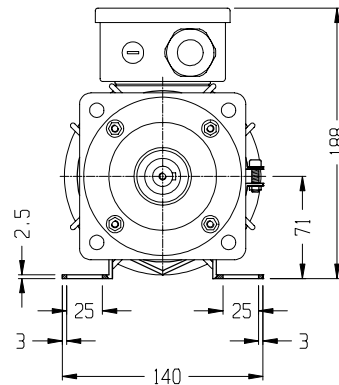
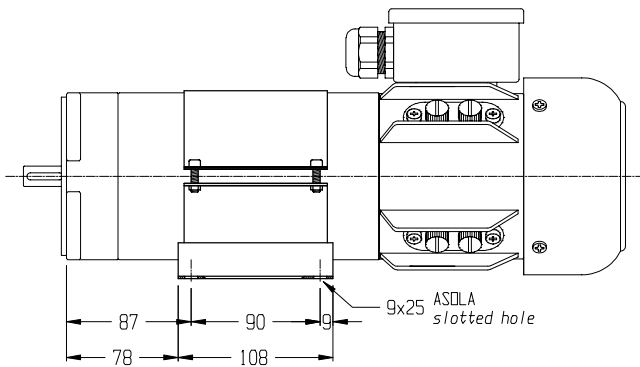

SOLO TAGLIA M
ONLY TYPE M

PIEDE A FASCIA

FOOT BAND TYPE

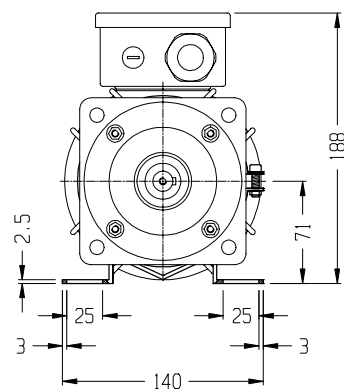
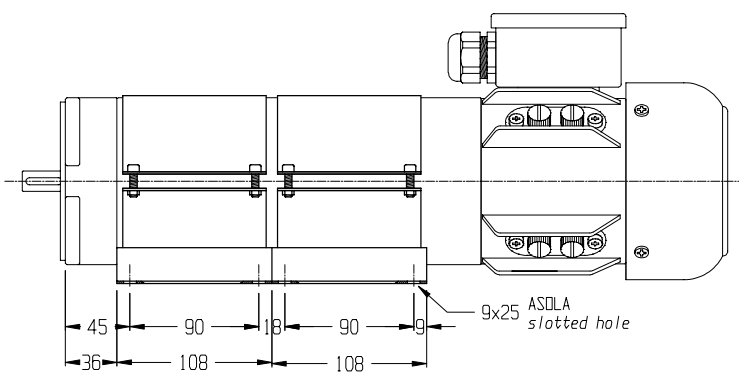

SOLO TAGLIA L
ONLY TYPE L

PENTA 7A

MOTORI C.C.

D.C. MOTORS

OPTIONALS

DIN. TACHIMETRICA TACHO GENERATOR

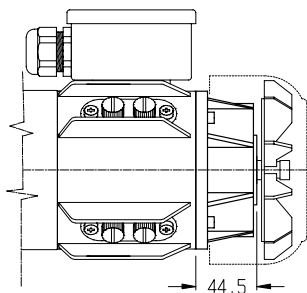

LA LUNGHEZZA TOTALE DEL MOTORE AUMENTA DI 10 mm

COSTANTE DI TENSIONE <i>VOLTAGE CONSTANT</i>	10±5% V/KRPM	CORRENTE NOMINALE <i>RATED CURRENT</i>	2 mA
VELOCITA' MASSIMA <i>MAX SPEED</i>	9000 RPM	CORRENTE MASSIMA <i>MAX CURRENT</i>	8 mA

FRENO 8 Nm BRAKE 8 Nm

BRAKE 8 Nm

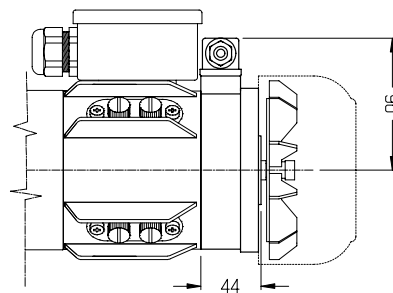

LA LUNGHEZZA TOTALE DEL MOTORE AUMENTA DI 42 mm

COPPIA STATICA <i>STATIC TORQUE</i>	8 Nm	CORRENTE <i>CURRENT</i>	1-0.13 A
TENSIONE DI ALIMEN. <i>POWER SUPPLY VOLTAGE</i>	24-190 V.c.c.	POTENZA ASSORBITA <i>INPUT POWER</i>	24 W